

B1 PREDATOR M50

NET BASED VEHICLE ARRESTOR - MODEL VA-NET-300

CRASH TESTED TO ASTM F2656-07 - M50/P2 RATED - STOPS 15,000 LB. VEHICLE AT 50 MPH IMPACT

VEHICLE ARRESTOR ELEVATION VIEW

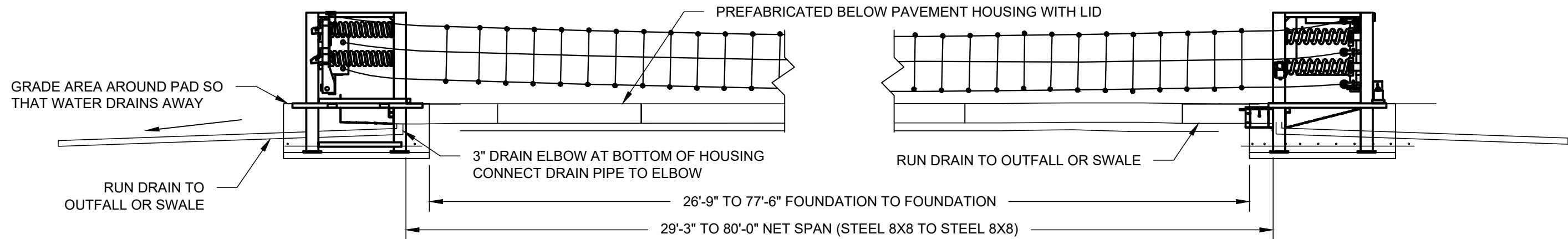

BELOW PAVEMENT HOUSING

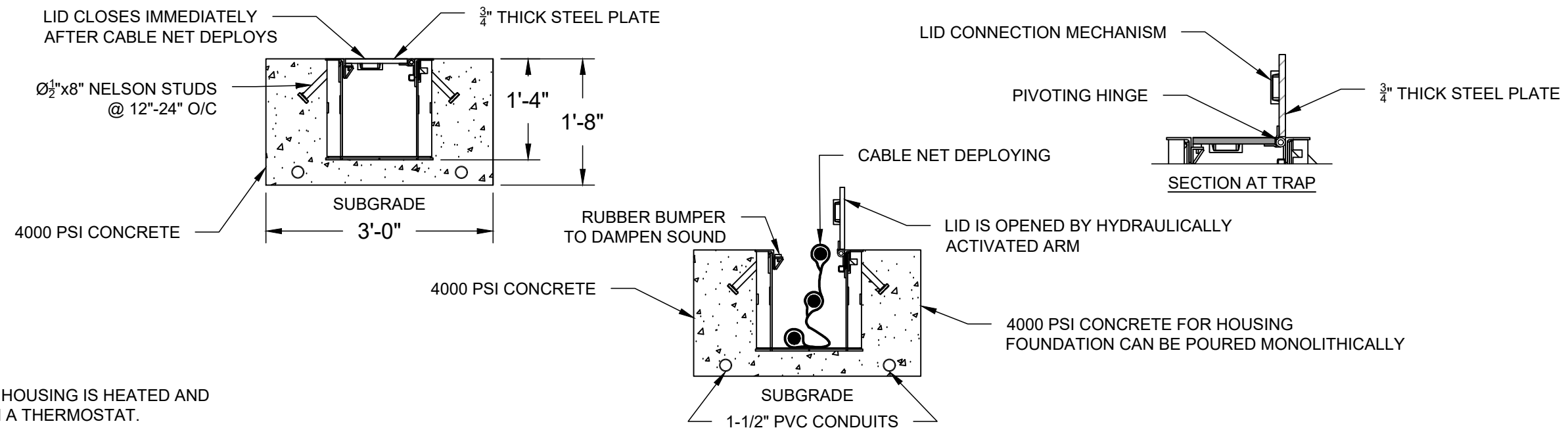

NOTE:

1. BELOW PAVEMENT HOUSING IS HEATED AND CONTROLLED WITH A THERMOSTAT.



BARRIER1 SYSTEMS, LLC

5335 US HWY 220
 SUMMERFIELD, NC 27358
 (336) 617-8478 www.barrier1.com
 sales@barrier1.com

PATENT PROTECTED

THE DRAWINGS AND INFORMATION CONTAINED HEREIN ARE PROPRIETARY AND CONFIDENTIAL, AND ARE AUTHORIZED ONLY FOR USE FOR WORK ASSOCIATED WITH BARRIER1 SYSTEMS, LLC ALL RIGHTS RESERVED.

VEHICLE ARRESTOR ELEVATION
 VIEW AND DETAIL
 (1 OF 3)

VA-NET-300
 WEBSITE DRAWING

SHEET: 1 OF 14

20241218-10-W

SCALE: N.T.S.

B1 PREDATOR M50

NET BASED VEHICLE ARRESTOR - MODEL VA-NET-300

CRASH TESTED TO ASTM F2656-07 - M50/P2 RATED - STOPS 15,000 LB. VEHICLE AT 50 MPH IMPACT

TYPICAL END SUPPORT SECTIONS - CONTROL SIDE

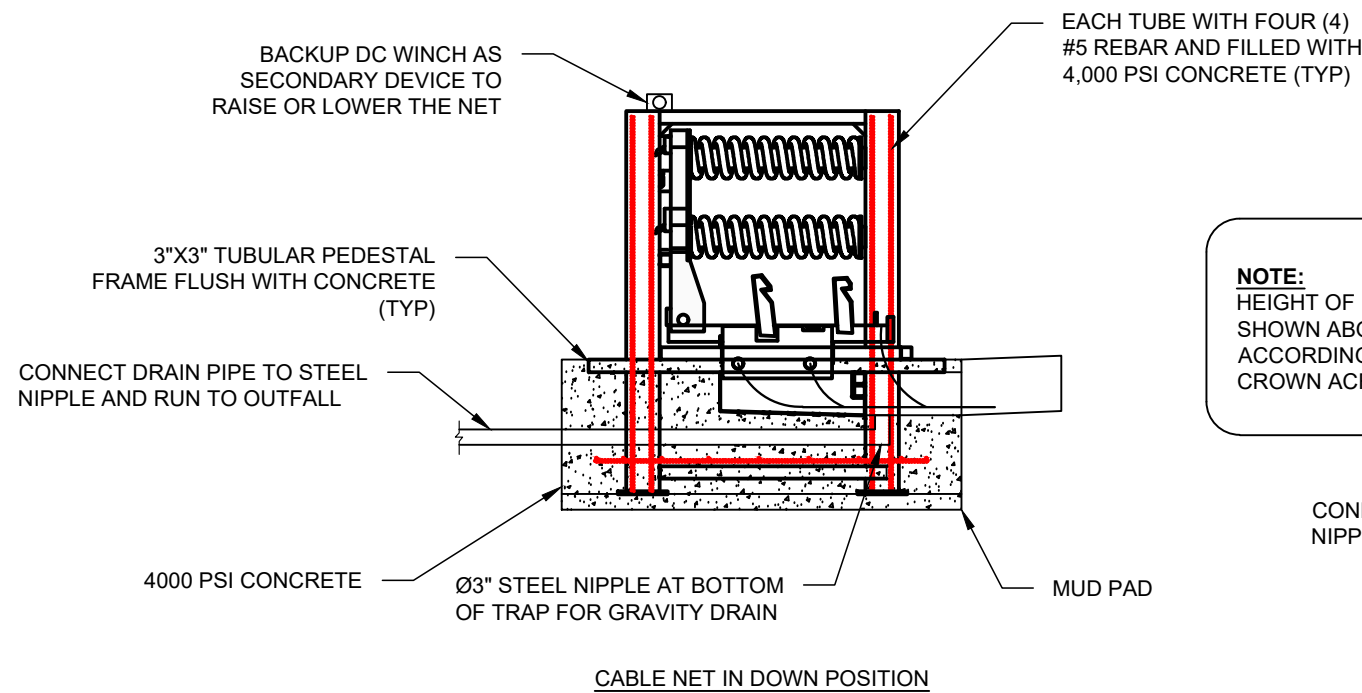

NOTE:
HEIGHT OF HORIZONTAL CABLES SHOWN ABOVE WILL VARY ACCORDING TO PAVEMENT CROWN ACROSS ROAD.

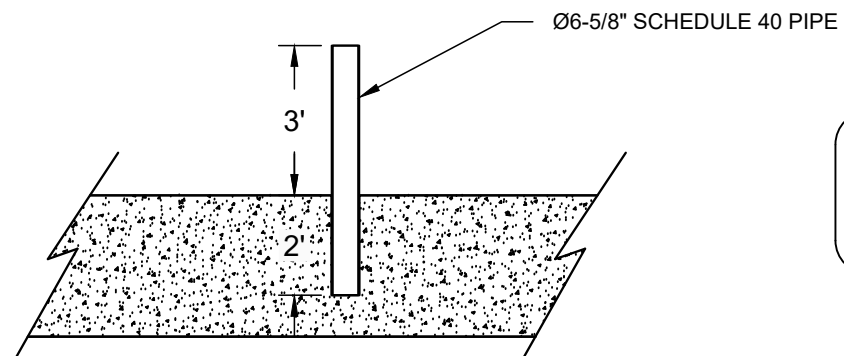
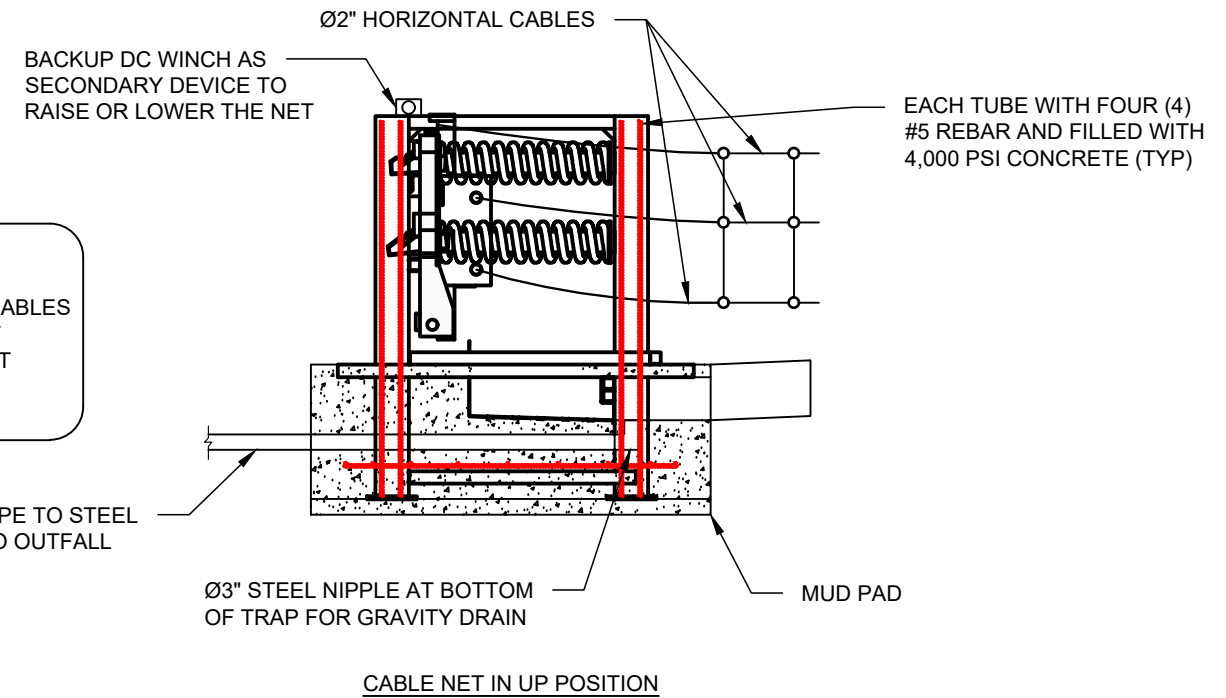

NOTE:
ADJUST REBAR SPACING IN FIELD AS NEEDED TO MISS 8X8 VERTICAL TUBE

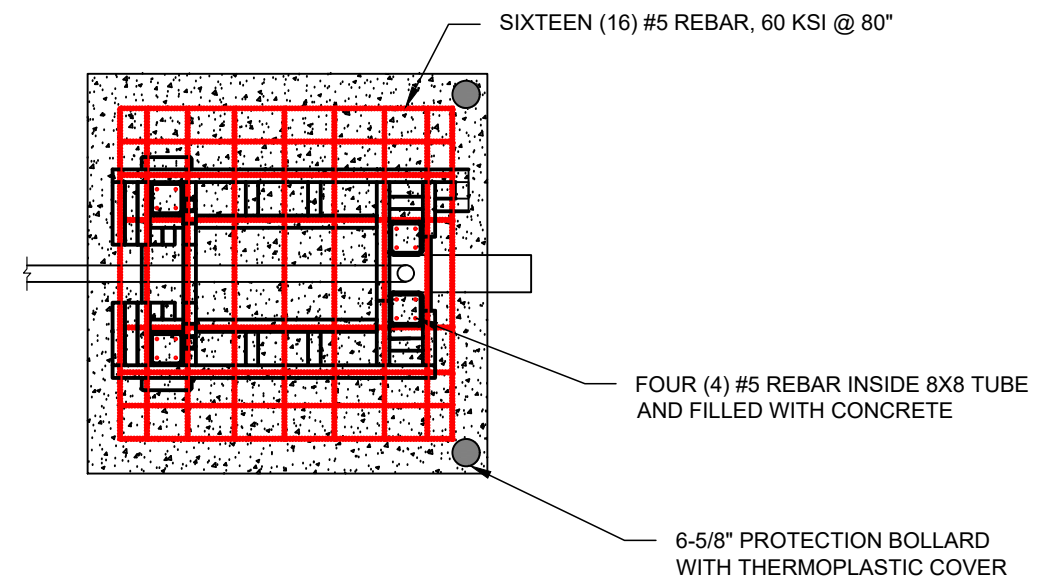

BARRIER1 SYSTEMS, LLC
5335 US HWY 220
SUMMERFIELD, NC 27358
(336) 617-8478 www.barrier1.com
sales@barrier1.com

PATENT PROTECTED

THE DRAWINGS AND INFORMATION CONTAINED HEREIN ARE PROPRIETARY AND CONFIDENTIAL, AND ARE AUTHORIZED ONLY FOR USE FOR WORK ASSOCIATED WITH BARRIER1 SYSTEMS, LLC ALL RIGHTS RESERVED.

VEHICLE ARRESTOR ELEVATION
VIEW AND DETAIL
(2 OF 3)

VA-NET-300
WEBSITE DRAWING

SHEET: 2 OF 14

20241218-10-W

SCALE: N.T.S.

B1 PREDATOR M50

NET BASED VEHICLE ARRESTOR - MODEL VA-NET-300

CRASH TESTED TO ASTM F2656-07 - M50/P2 RATED - STOPS 15,000 LB. VEHICLE AT 50 MPH IMPACT

TYPICAL END SUPPORT SECTIONS - STATIC SIDE

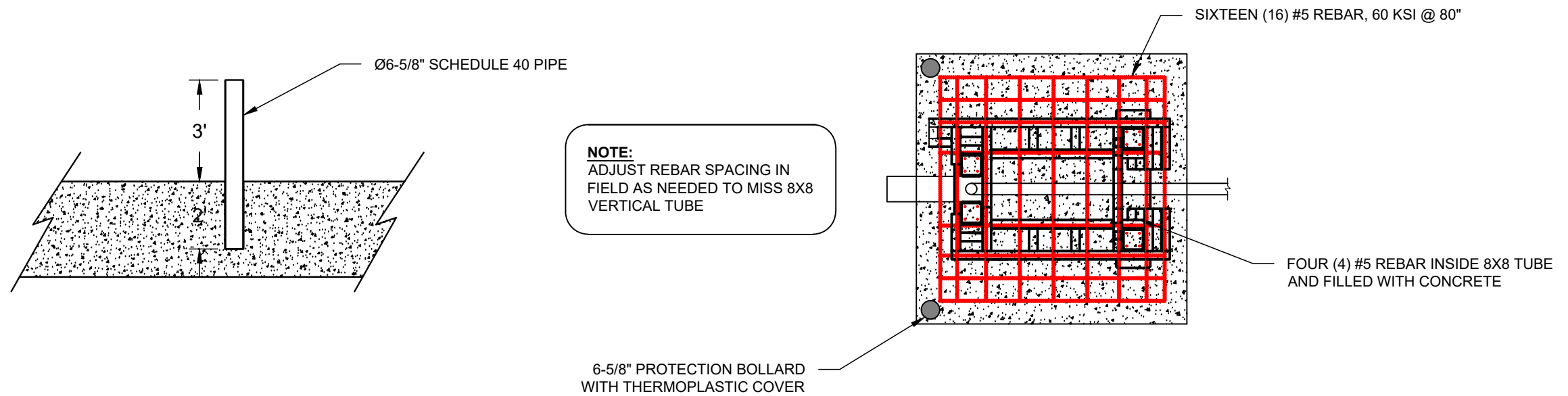
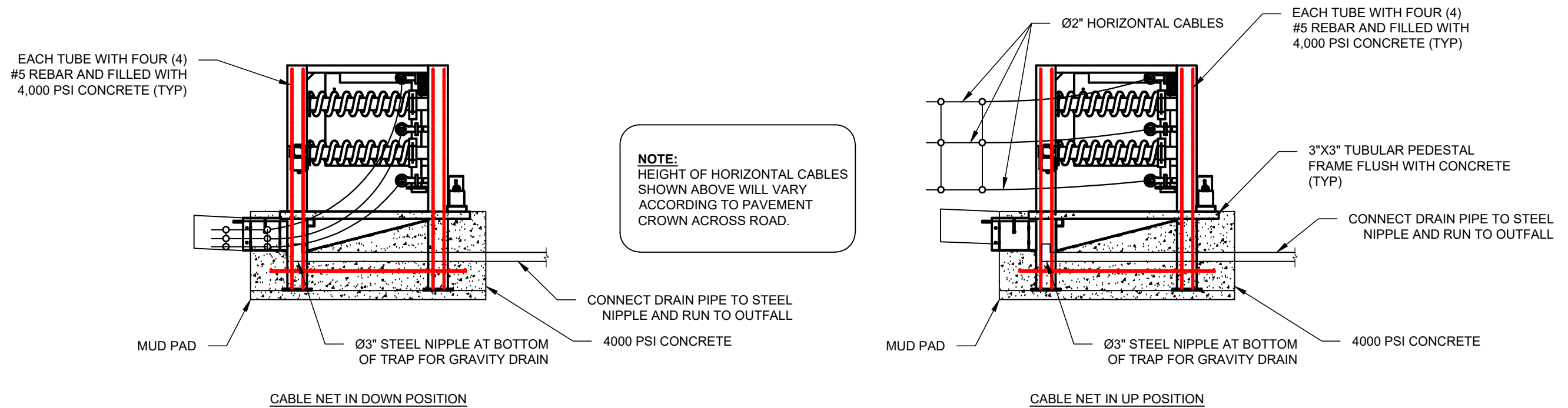

BARRIER1 SYSTEMS, LLC

5335 US HWY 220
SUMMERFIELD, NC 27358
(336) 617-8478 www.barrier1.com
sales@barrier1.com

PATENT PROTECTED

THE DRAWINGS AND INFORMATION CONTAINED HEREIN ARE PROPRIETARY AND CONFIDENTIAL, AND ARE AUTHORIZED ONLY FOR USE FOR WORK ASSOCIATED WITH BARRIER1 SYSTEMS, LLC ALL RIGHTS RESERVED.

VEHICLE ARRESTOR ELEVATION
VIEW AND DETAIL
(3 OF 3)

VA-NET-300
WEBSITE DRAWING

SHEET: 3 OF 14

20241218-10-W

SCALE: N.T.S.

B1 PREDATOR M50

NET BASED VEHICLE ARRESTOR - MODEL VA-NET-300

CRASH TESTED TO ASTM F2656-07 - M50/P2 RATED - STOPS 15,000 LB. VEHICLE AT 50 MPH IMPACT

TRAFFIC SIGNALS, WARNING LIGHTS, AND SIGNS

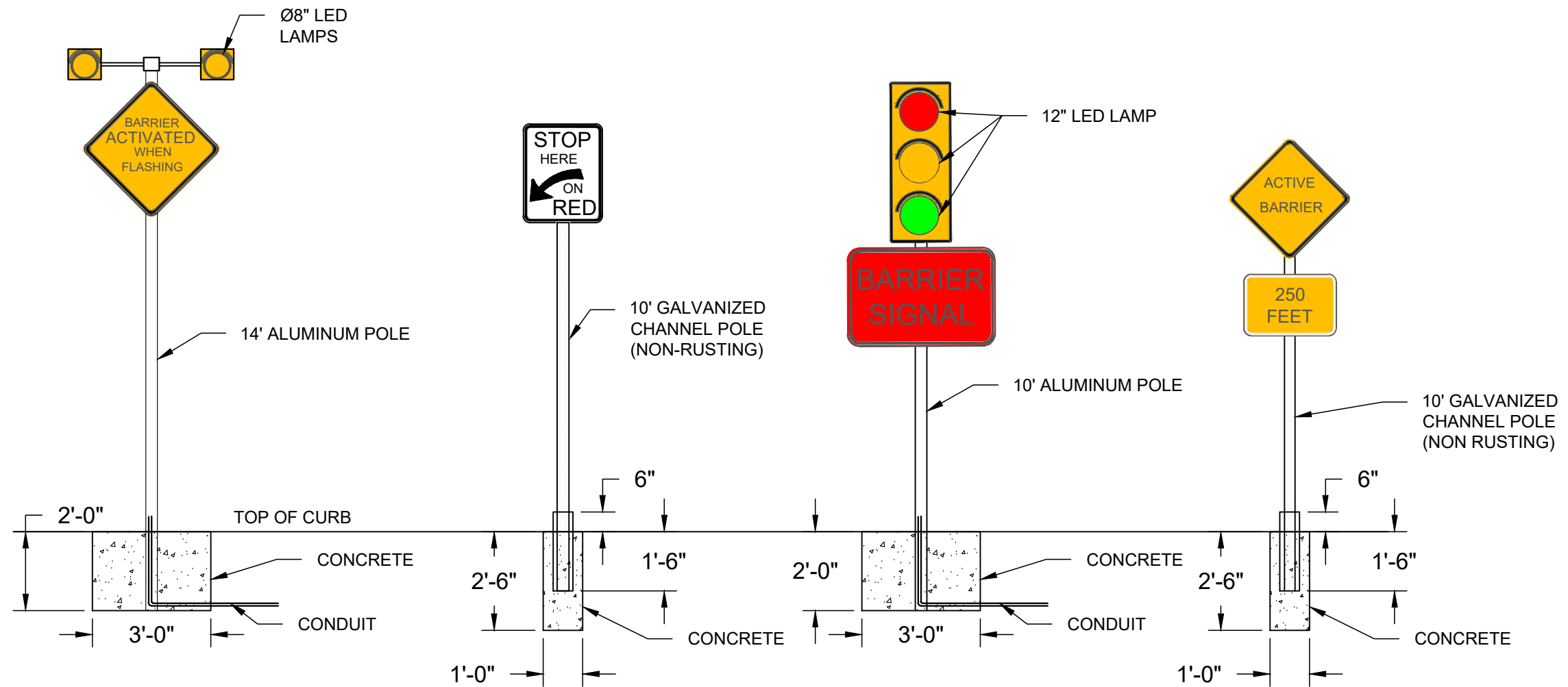

NOTE:

1. ON BOARD UPS BATTERY BACKUP POWER PROVIDED FOR ACTUATORS, LIGHTS, SIGNALS, CONTROL PANELS, DEVICES, ETC. IF POWER OUTAGE OCCURS. (10+ CYCLES OVER 2 HOURS)
2. TRAFFIC SIGNAL AND "BARRIER SIGNAL" SIGN INSTALLED ON POLE AND/OR MAST ARM.
3. SIGNS ARE DIAMOND GRADE AND RETRO REFLECTIVE.
4. ALL LIGHTS ARE 24VDC LED LIGHTS.
5. BARRIER 1 ONLY TO SUPPLY SIGNS SHOWN ON THIS PAGE.



BARRIER1 SYSTEMS, LLC

5335 US HWY 220
 SUMMERFIELD, NC 27358
 (336) 617-8478 www.barrier1.com
 sales@barrier1.com

PATENT PROTECTED

THE DRAWINGS AND INFORMATION CONTAINED HEREIN ARE PROPRIETARY AND CONFIDENTIAL, AND ARE AUTHORIZED ONLY FOR USE FOR WORK ASSOCIATED WITH BARRIER1 SYSTEMS, LLC ALL RIGHTS RESERVED.

SIGNS AND SIGNAL ELEVATIONS

VA-NET-300 WEBSITE DRAWING

SHEET: 4 OF 14

20241218-10-W

SCALE: N.T.S.

B1 PREDATOR M50

NET BASED VEHICLE ARRESTOR - MODEL VA-NET-300

CRASH TESTED TO ASTM F2656-07 - M50/P2 RATED - STOPS 15,000 LB. VEHICLE AT 50 MPH IMPACT

CONDUITS AND ENCLOSURES SCHEMATIC

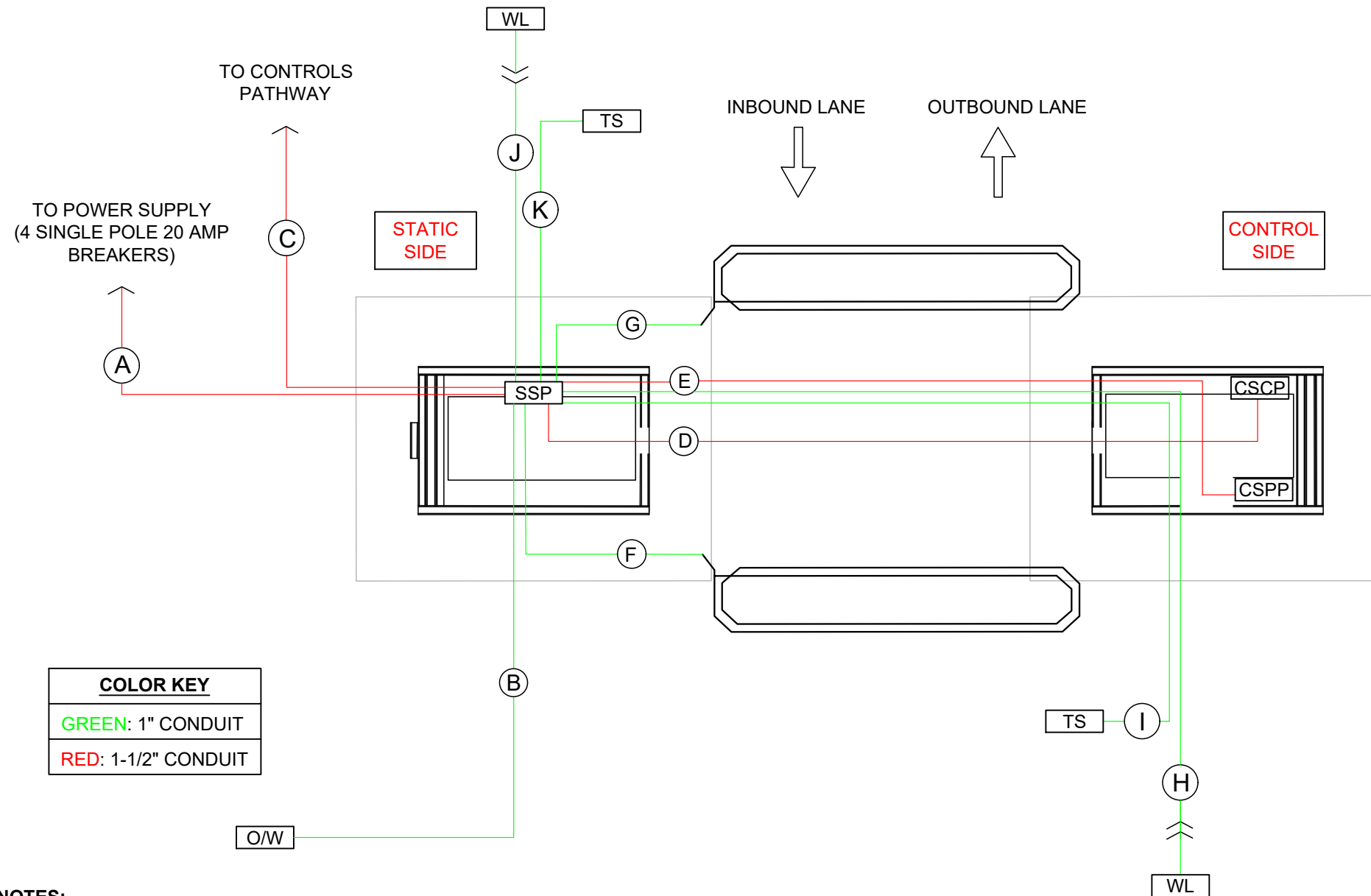

CONDUIT SCHEDULE		
CONDUIT LABEL	CONDUIT DIAMETER	WIRE
(A)	1 1/2"	FOUR (4) 120VAC/20A CIRCUITS
(B)	1 1/2"	CAT-6 NETWORK CABLE
(C)	1 1/2"	6 STRAND MULTI-MODE FIBER
(D)	1 1/2"	18 GAUGE, 25 CONDUCTOR
(E)	1 1/2"	TWO (2) 120VAC/20A CIRCUITS
(F)	1"	14 GAUGE, XHHW,
(G)	1"	14 GAUGE, XHHW,
(H)	1"	18 GAUGE, 3 CONDUCTOR
(I)	1"	18 GAUGE, 4 CONDUCTOR
(J)	1"	18 GAUGE, 3 CONDUCTOR
(K)	1"	18 GAUGE, 4 CONDUCTOR

SYMBOLS	SYMBOL KEY
WL	WARNING LIGHTS
OW	OVERWATCH PANEL
SSP	CONTROLS PANEL, IN STATIC SIDE END SUPPORT
CSPP	POWER PANEL, IN CONTROLS SIDE END SUPPORT
CSCP	CONTROLS PANEL, IN CONTROLS SIDE END SUPPORT
TS	TRAFFIC SIGNAL

NOTES:

1. STUB CONDUITS OUTSIDE OF CONCRETE LIMITS AND CAP OFF ENDS BEFORE POURING.
2. INSTALL ALL CONDUITS AND PULL WIRE PER SCHEDULE.
3. ELECTRICAL WORK TO COMPLY WITH LOCAL CODES AND REQUIREMENTS.
4. THIS SCHEMATIC SHOWS GENERAL ROUTING. EXACT LOCATIONS OF CONDUIT, TERMINATIONS, SUBPANEL, CONNECTIONS, PULL BOXES, ETC. T.B.D. BY ELECTRICIAN.



BARRIER1 SYSTEMS, LLC

5335 US HWY 220
 SUMMERFIELD, NC 27358
 (336) 617-8478 www.barrier1.com
 sales@barrier1.com

PATENT PROTECTED

THE DRAWINGS AND INFORMATION CONTAINED HEREIN ARE PROPRIETARY AND CONFIDENTIAL, AND ARE AUTHORIZED ONLY FOR USE FOR WORK ASSOCIATED WITH BARRIER1 SYSTEMS, LLC ALL RIGHTS RESERVED.

CONDUIT LAYOUT

VA-NET-300
 WEBSITE DRAWING

SHEET: 5 OF 14

20241218-10-W

SCALE: N.T.S.

B1 PREDATOR M50

NET BASED VEHICLE ARRESTOR - MODEL VA-NET-300

CRASH TESTED TO ASTM F2656-07 - M50/P2 RATED - STOPS 15,000 LB. VEHICLE AT 50 MPH IMPACT

CONDUITS AND ENCLOSURE DIAGRAM

TYPICAL BARRIER ENCLOSURES AND CONDUITS			
CONDUIT LABEL	CONDUIT SCHEDULE SIZE & DESCRIPTION	FROM	TO
A	FOUR (4) 120VAC/20A CIRCUITS	POWER SUPPLY	SSP
B	1 1/2" CAT-6 NETWORK CABLE	SSP	OVERWATCH (O/W)
C	1 1/2" 6 STRAND MULTI-MODE FIBER	SSP	GUARDHOUSE
D	1 1/2" 18 GAUGE, 25 CONDUCTOR	SSP	CSCP
E	TWO (2) 120VAC/20A CIRCUITS	SSP	CSPP
F	1" 14 GAUGE, XHHW	SSP	SAFETY LOOP
G	1" 14 GAUGE, XHHW	SSP	SAFETY LOOP
H	1" 18 GAUGE, 3 CONDUCTOR	SSP	WARNING LIGHT (WL)
I	1" 18 GAUGE, 4 CONDUCTOR	SSP	TRAFFIC SIGNAL (TS)
J	1" 18 GAUGE, 3 CONDUCTOR	SSP	WARNING LIGHT (WL)
K	1" 18 GAUGE, 4 CONDUCTOR	SSP	TRAFFIC SIGNAL (TS)

CONTROL SIDE - POWER ENCLOSURE (CSPP)
LOCATED INSIDE POWER SIDE END SUPPORT

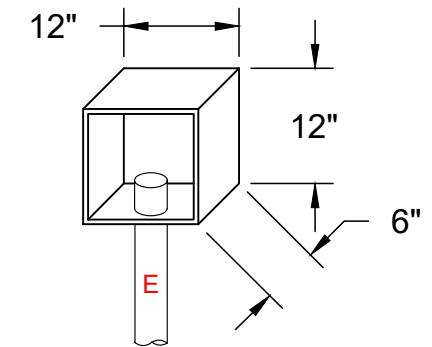

STATIC SIDE - CONTROLS ENCLOSURE (SSP)
LOCATED INSIDE STATIC SIDE END SUPPORT

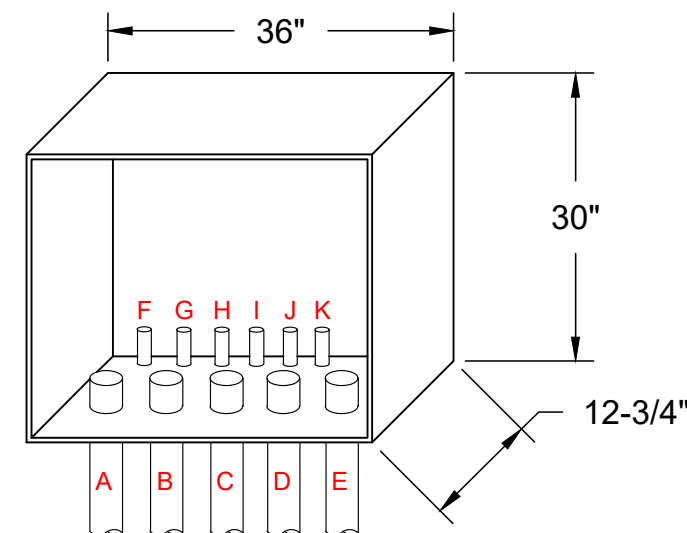

CONTROL SIDE - CONTROLS ENCLOSURE (CSCP)
LOCATED INSIDE POWER SIDE END SUPPORT

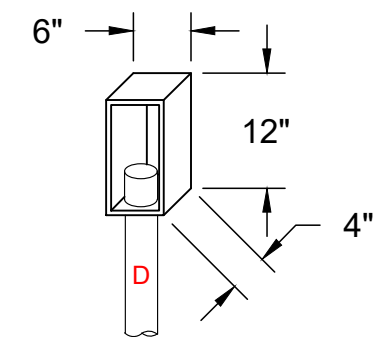

NOTES:

1. PVC CONDUITS ARE PRE-INSTALLED BY BARRIER1 SYSTEMS. PVC CONDUITS ARE PREINSTALLED TO 6" BELOW TOP OF CONCRETE INSIDE EACH END SUPPORT. ELECTRICAL CONTRACTOR TO CONNECT AND RUN OUTSIDE FOUNDATION PRIOR TO POURING CONCRETE.
2. ALL RISER CONDUITS SHALL BE PVC CONDUIT. PVC CONDUIT MAY BE USED FOR UNDERGROUND INSTALLATION.
3. BARRIER1 TO COMPLY WITH CODES AND SITE REQUIREMENTS REGARDING CONDUIT TYPES, MATERIALS, CONNECTIONS, DEPTHS AND OTHER REQUIREMENTS.



BARRIER1 SYSTEMS, LLC

5335 US HWY 220
SUMMERFIELD, NC 27358
(336) 617-8478 www.barrier1.com
sales@barrier1.com

PATENT PROTECTED

THE DRAWINGS AND INFORMATION CONTAINED HEREIN ARE PROPRIETARY AND CONFIDENTIAL, AND ARE AUTHORIZED ONLY FOR USE FOR WORK ASSOCIATED WITH BARRIER1 SYSTEMS, LLC ALL RIGHTS RESERVED.

CONDUIT AND
ENCLOSURE DIAGRAM

VA-NET-300
WEBSITE DRAWING

SHEET: 6 OF 14

20241218-10-W

SCALE: N.T.S.

B1 PREDATOR M50

NET BASED VEHICLE ARRESTOR - MODEL VA-NET-300

CRASH TESTED TO ASTM F2656-07 - M50/P2 RATED - STOPS 15,000 LB. VEHICLE AT 50 MPH IMPACT

SAFETY LOOP DETAILS - PLAN VIEW

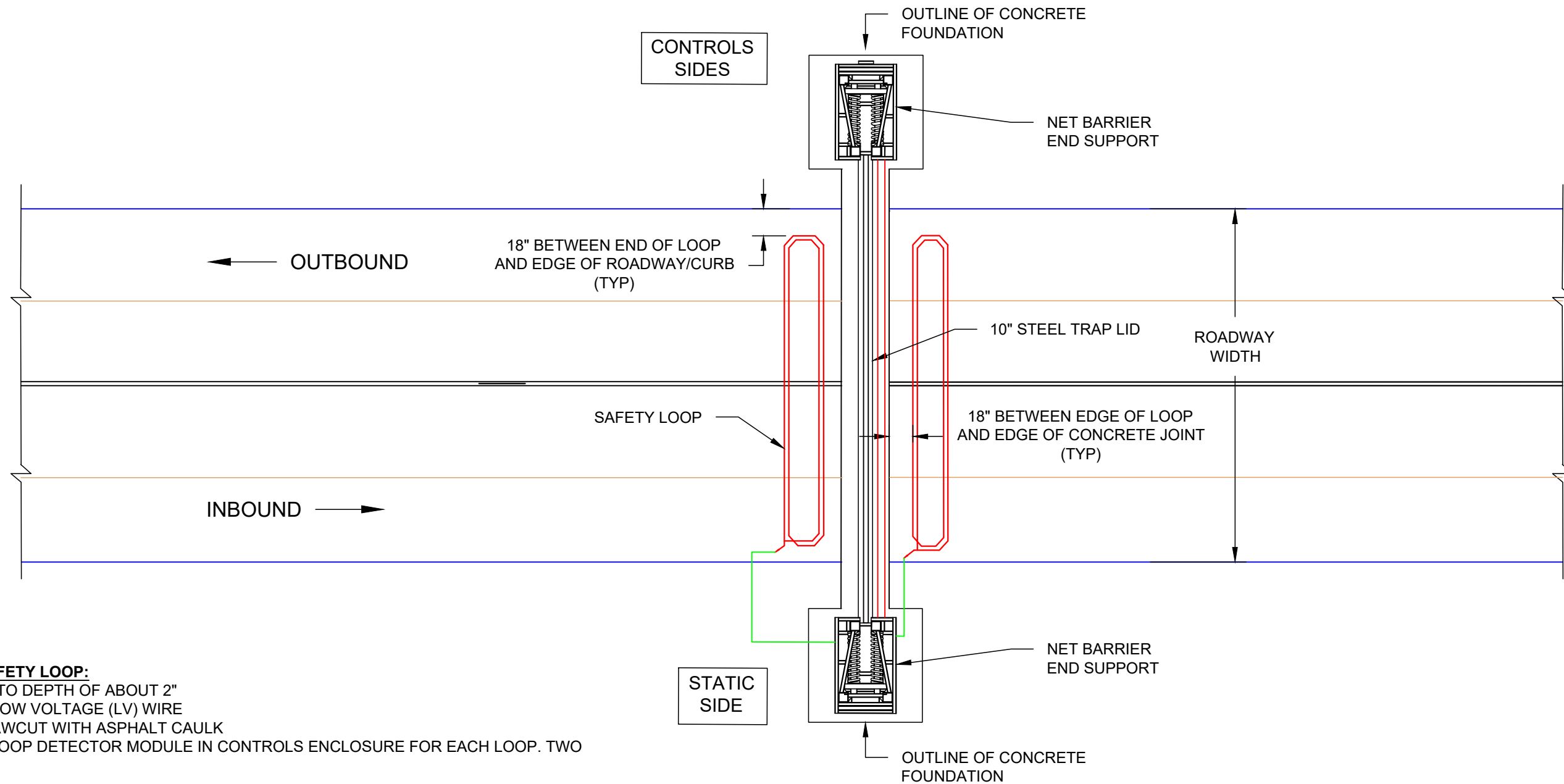

NOTES FOR SAFETY LOOP:

1. SAWCUT TO DEPTH OF ABOUT 2"
2. INSTALL LOW VOLTAGE (LV) WIRE
3. CAULK SAWCUT WITH ASPHALT CAULK
4. SAFETY LOOP DETECTOR MODULE IN CONTROLS ENCLOSURE FOR EACH LOOP. TWO (2 TOTAL)



BARRIER1 SYSTEMS, LLC

5335 US HWY 220
 SUMMERFIELD, NC 27358
 (336) 617-8478 www.barrier1.com
 sales@barrier1.com

PATENT PROTECTED

THE DRAWINGS AND INFORMATION CONTAINED HEREIN ARE PROPRIETARY AND CONFIDENTIAL, AND ARE AUTHORIZED ONLY FOR USE FOR WORK ASSOCIATED WITH BARRIER1 SYSTEMS, LLC ALL RIGHTS RESERVED.

SAFETY LOOP DETAIL

VA-NET-300
 WEBSITE DRAWING

SHEET: 7 OF 14

20241218-10-W

SCALE: N.T.S.

B1 PREDATOR M50

NET BASED VEHICLE ARRESTOR - MODEL VA-NET-300

CRASH TESTED TO ASTM F2656-07 - M50/P2 RATED - STOPS 15,000 LB. VEHICLE AT 50 MPH IMPACT

CONTROLS COMMUNICATION CABLING

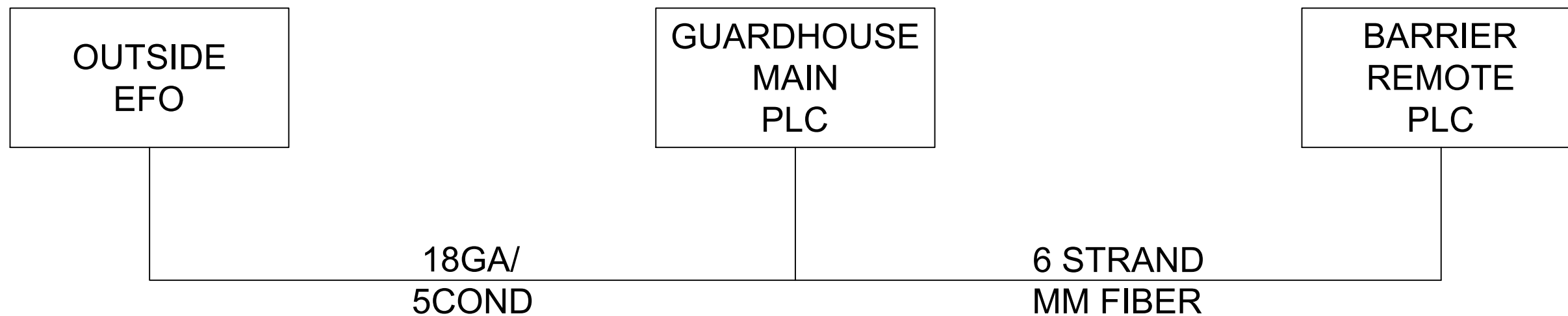

BARRIER1 SYSTEMS, LLC

5335 US HWY 220
SUMMERFIELD, NC 27358
(336) 617-8478 www.barrier1.com
sales@barrier1.com

PATENT PROTECTED

THE DRAWINGS AND INFORMATION CONTAINED HEREIN ARE PROPRIETARY AND CONFIDENTIAL, AND ARE AUTHORIZED ONLY FOR USE FOR WORK ASSOCIATED WITH BARRIER1 SYSTEMS, LLC ALL RIGHTS RESERVED.

NET BARRIER SITE
COMMUNICATION CABLING

VA-NET-300
WEBSITE DRAWING

SHEET: 8 OF 14

20241218-10-W

SCALE: N.T.S.

B1 PREDATOR M50

NET BASED VEHICLE ARRESTOR - MODEL VA-NET-300

CRASH TESTED TO ASTM F2656-07 - M50/P2 RATED - STOPS 15,000 LB. VEHICLE AT 50 MPH IMPACT

NET BARRIER MASTER CONTROL PANEL (LOCATED INSIDE EXISTING GUARDBOUSE)

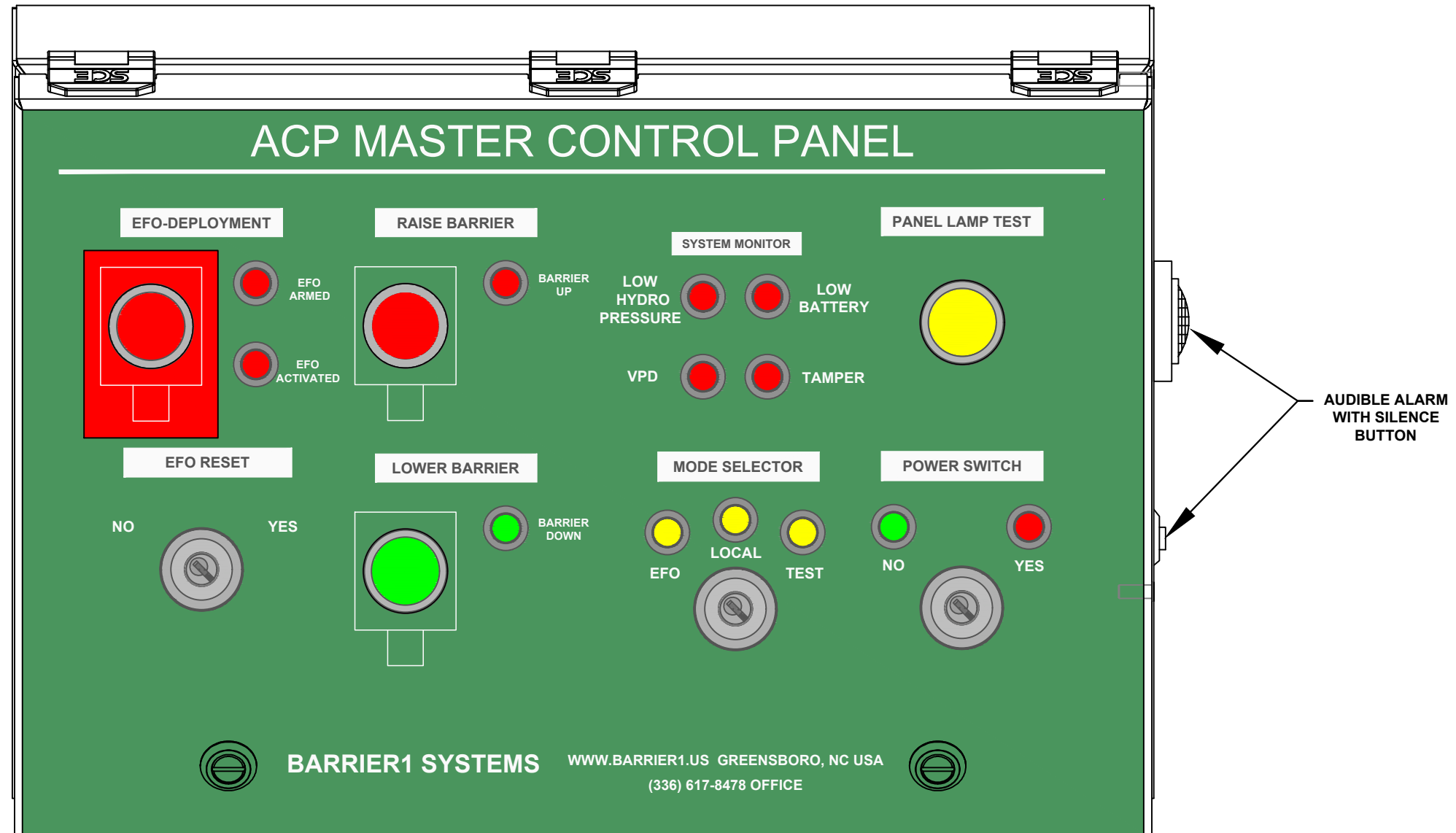

NOTE:

1. WHEN DOING MAINTENANCE, PLACE IN "LOCAL MODE" SO BARRIER DEPLOYMENT IS LOCKED OUT AT GUARD HOUSE. IT CAN BE DEPLOYED LOCALLY, AT BARRIER.
2. TAMPER SWITCH IS ON ALL END SUPPORT ENCLOSURE DOORS.
3. IF VEHICLE SITS ON SAFETY LOOP FOR 10 SECONDS, VPD INDICATOR LIGHT & AUDIBLE ALARM ACTIVATE. THIS ACTIVATION TIME CAN BE ADJUSTED.
4. EFO ACTIVATED LIGHT PROGRAMMED TO ILLUMINATE ONCE ANY EFO SIGNAL HAS BEEN RECEIVED.



BARRIER1 SYSTEMS, LLC

5335 US HWY 220
SUMMERFIELD, NC 27358
(336) 617-8478 www.barrier1.com
sales@barrier1.com

PATENT PROTECTED

THE DRAWINGS AND INFORMATION CONTAINED HEREIN ARE PROPRIETARY AND CONFIDENTIAL, AND ARE AUTHORIZED ONLY FOR USE FOR WORK ASSOCIATED WITH BARRIER1 SYSTEMS, LLC ALL RIGHTS RESERVED.

NET BARRIER
MASTER CONTROL PANEL

VA-NET-300
WEBSITE DRAWING

SHEET: 9 OF 14

20241218-10-W

SCALE: N.T.S.

B1 PREDATOR M50

NET BASED VEHICLE ARRESTOR - MODEL VA-NET-300

CRASH TESTED TO ASTM F2656-07 - M50/P2 RATED - STOPS 15,000 LB. VEHICLE AT 50 MPH IMPACT

NET BARRIER EFO BUTTON ENCLOSURE

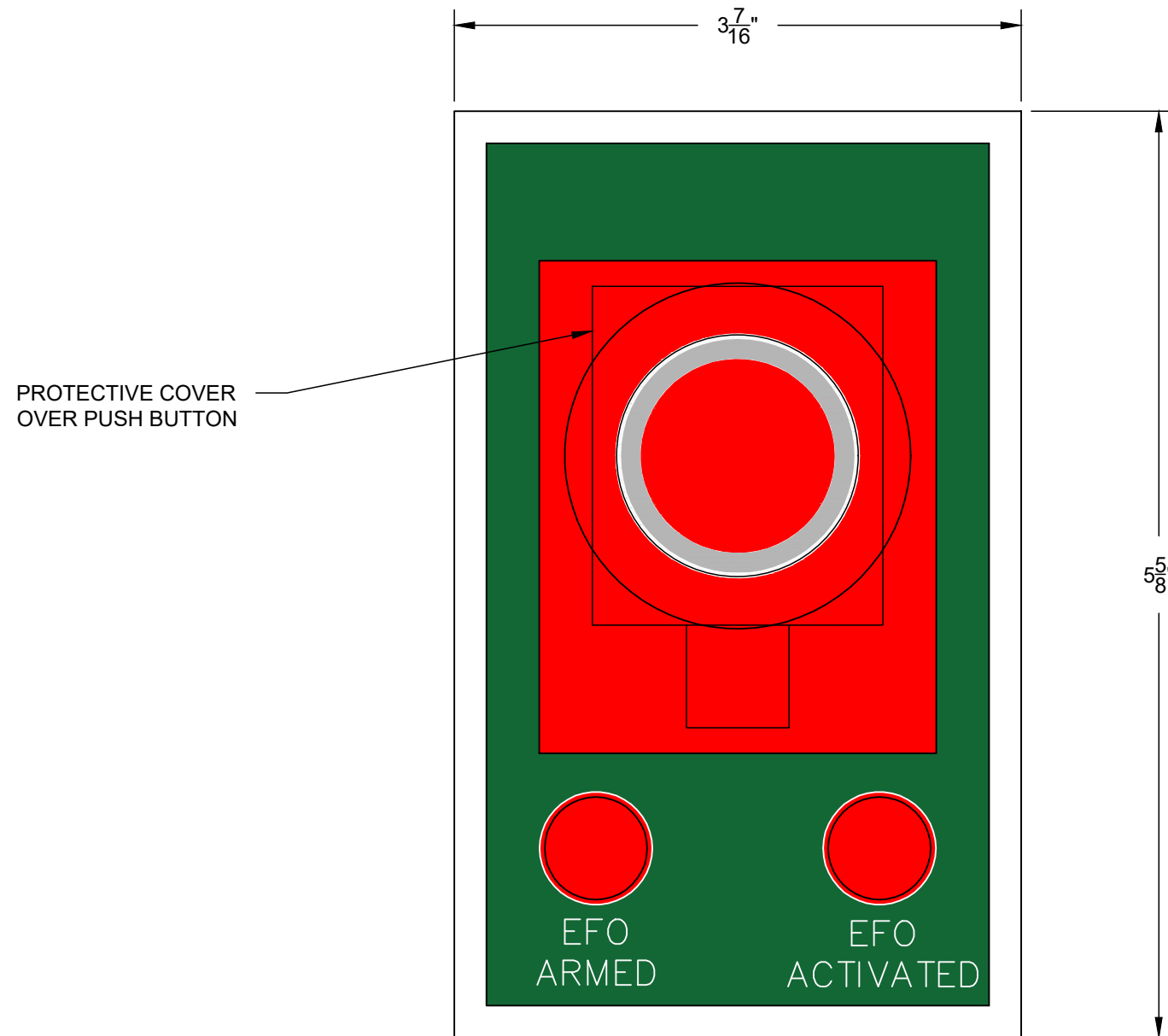

NOTE:

1. EFO ACTIVATED LIGHT PROGRAMMED TO ILLUMINATE ONCE ANY EFO SIGNAL HAS BEEN RECEIVED.



BARRIER1 SYSTEMS, LLC

5335 US HWY 220
SUMMERFIELD, NC 27358
(336) 617-8478 www.barrier1.com
sales@barrier1.com

PATENT PROTECTED

THE DRAWINGS AND INFORMATION CONTAINED HEREIN ARE PROPRIETARY AND CONFIDENTIAL, AND ARE AUTHORIZED ONLY FOR USE FOR WORK ASSOCIATED WITH BARRIER1 SYSTEMS, LLC ALL RIGHTS RESERVED.

NET BARRIER
EFO ENCLOSURE

VA-NET-300
WEBSITE DRAWING

SHEET: 10 OF 14

20241218-10-W

SCALE: N.T.S.

B1 PREDATOR M50

NET BASED VEHICLE ARRESTOR - MODEL VA-NET-300

CRASH TESTED TO ASTM F2656-07 - M50/P2 RATED - STOPS 15,000 LB. VEHICLE AT 50 MPH IMPACT

LOCAL BARRIER CONTROLLERS

HAND HELD MAINTENANCE CONTROLLER



LOCAL CONTROLLER

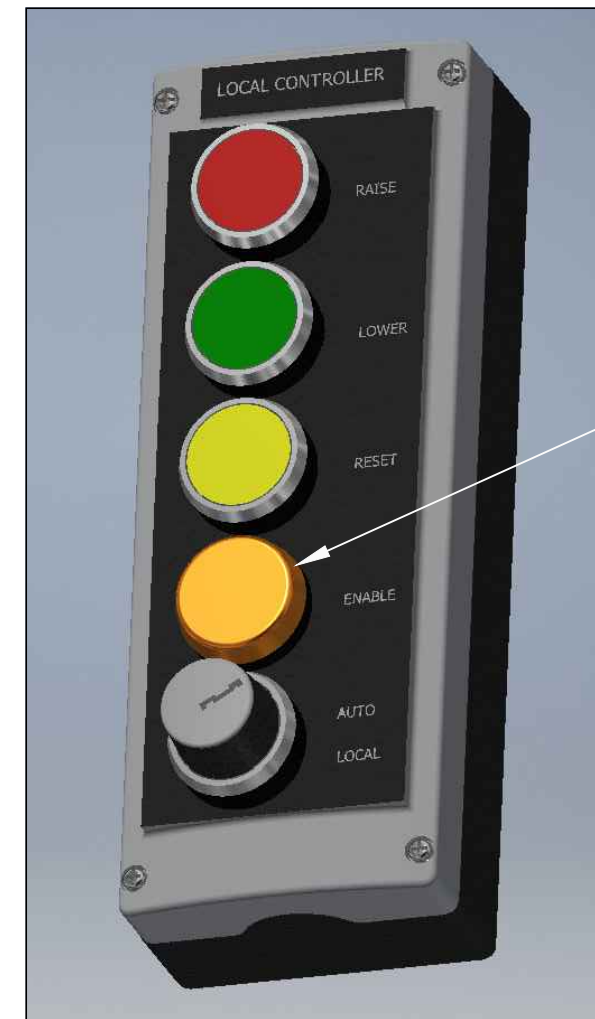

LAMP INDICATES THAT LOCAL CONTROLLER HAS BEEN ENABLED AT MASTER CONTROL PANEL.

NOTE:

1. MAINTENANCE CONTROLLER ALLOWS INDIVIDUAL FUNCTIONS TO BE PERFORMED.
2. MAINTENANCE CONTROLLER IS LOCKED INSIDE OF END SUPPORT ENCLOSURE.
3. YELLOW RESET BUTTON ON LOCAL CONTROLLER WILL RESET A HYDRAULIC MOTOR TIMEOUT, INDICATED ON MASTER CONTROL PANEL.



BARRIER1 SYSTEMS, LLC

5335 US HWY 220
SUMMERFIELD, NC 27358
(336) 617-8478 www.barrier1.com
sales@barrier1.com

PATENT PROTECTED

THE DRAWINGS AND INFORMATION CONTAINED HEREIN ARE PROPRIETARY AND CONFIDENTIAL, AND ARE AUTHORIZED ONLY FOR USE FOR WORK ASSOCIATED WITH BARRIER1 SYSTEMS, LLC ALL RIGHTS RESERVED.

LOCAL NET BARRIER CONTROLS

VA-NET-300 WEBSITE DRAWING

SHEET: 11 OF 14

20241218-10-W

SCALE: N.T.S.

B1 PREDATOR M50

NET BASED VEHICLE ARRESTOR - MODEL VA-NET-300

CRASH TESTED TO ASTM F2656-07 - M50/P2 RATED - STOPS 15,000 LB. VEHICLE AT 50 MPH IMPACT

SEQUENCING OF TRAFFIC SIGNALS, WARNING LIGHTS, AND ALARMS UPON FINAL DENIAL ACTIVATION

OPERATIONAL SEQUENCE PER SECOND (MIN. FOR SAFETY - 40 KPH (25MPH) DESIGN SPEED)

ELAPSED TIME	0	1	2	3	4	5	6	7	8	9	10
TRAFFIC CONTROLS AND SAFETY AT ACTIVE BARRIER	NORMAL OPERATION	GUARD PERCEPTION AND REACTION TIME TO THREAT (EFO BUTTON) - 3 SECONDS			YELLOW CLEARANCE - GET ACROSS BARRIER 3 SECONDS (MUTCD MINIMUM)			ALL RED	DEPLOYING BARRIER		THREAT CONTAINED
SIGN AND SIGNAL WARNING SYSTEM	WARNING SIGNS AND LIGHT WITH BEACONS	OFF	OFF	OFF	OFF	FLASHING YELLOW	FLASHING YELLOW	FLASHING YELLOW	FLASHING YELLOW	FLASHING YELLOW	FLASHING YELLOW
	TRAFFIC SIGNAL	GREEN	GREEN	GREEN	GREEN	YELLOW	YELLOW	YELLOW	RED	RED	RED
	AUDIBLE SIREN ALARM	OFF	OFF	OFF	OFF	ON	ON	ON	ON	ON	ON
	SAFETY LOOP DETECTORS	ON	ON	ON	ON	ON	ON	ON	ON	ON	ON
	ACTIVE BARRIER POSITION	DOWN	DOWN	DOWN	DOWN	DOWN	DOWN	DOWN	DOWN	ACTIVATED	ACTIVATED

NOTES:

1. SEQUENCING AND TIMING OF SIGNALS, ALARMS AND LIGHTS CAN BE FIELD ADJUSTED USING PLC.
2. SAFETY LOOP DETECTORS PREVENT DEPLOYMENT OF BARRIER IF A VEHICLE IS ABOVE LOOP. BARRIER DEPLOYS AFTER VEHICLE PASSES OVER THE SAFETY LOOPS.



BARRIER1 SYSTEMS, LLC
 5335 US HWY 220
 SUMMERFIELD, NC 27358
 (336) 617-8478 www.barrier1.com
 sales@barrier1.com

PATENT PROTECTED

THE DRAWINGS AND INFORMATION CONTAINED HEREIN ARE PROPRIETARY AND CONFIDENTIAL, AND ARE AUTHORIZED ONLY FOR USE FOR WORK ASSOCIATED WITH BARRIER1 SYSTEMS, LLC ALL RIGHTS RESERVED.

NET BARRIER TIME SEQUENCING DIAGRAM

VA-NET-300 WEBSITE DRAWING

SHEET: 12 OF 14

20241218-10-W

SCALE: N.T.S.

B1 PREDATOR M50

NET BASED VEHICLE ARRESTOR - MODEL VA-NET-300

CRASH TESTED TO ASTM F2656-07 - M50/P2 RATED - STOPS 15,000 LB. VEHICLE AT 50 MPH IMPACT

END SUPPORT ENCLOSURES AND LOCKING ACCESS DOORS

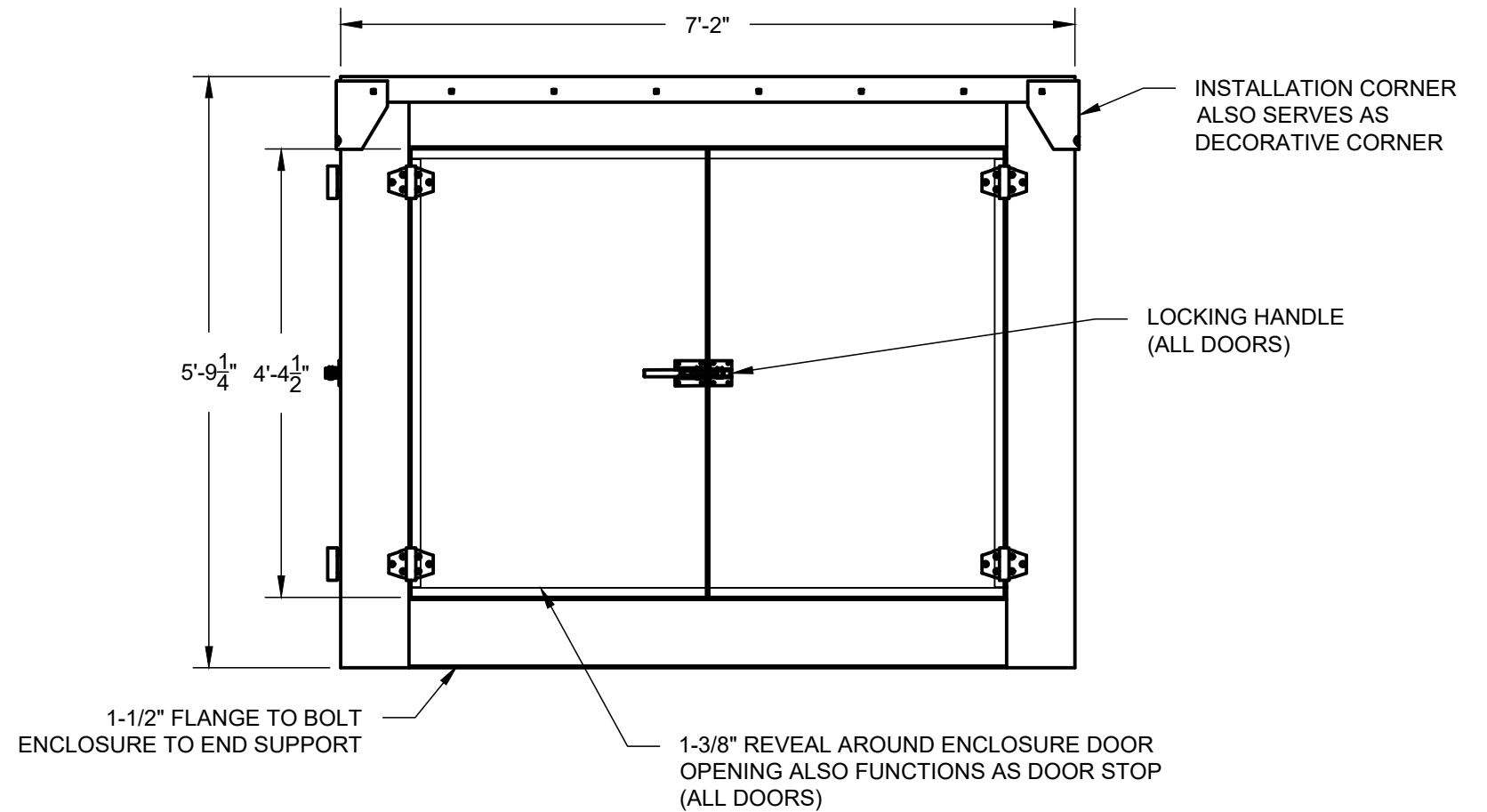
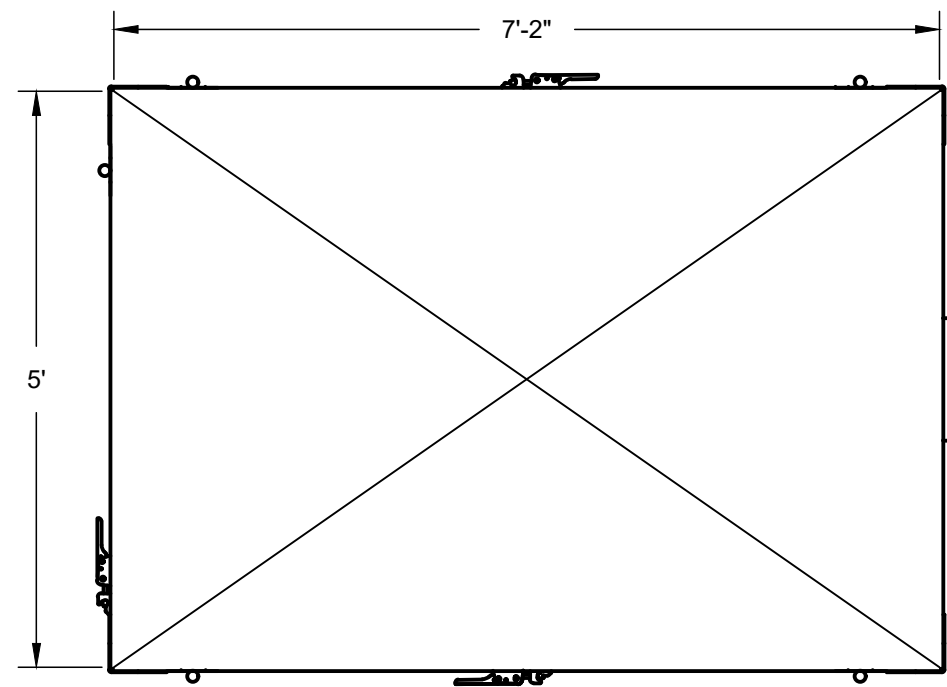

NOTES:

1. ENCLOSURE MATERIALS ARE 3/16" ALUMINUM WITH STANDARD PAINTED GRAY FINISH.
2. ENCLOSURES HAVE DOUBLE DOORS ON BOTH SIDES, AND A SINGLE DOOR IN REAR.



BARRIER1 SYSTEMS, LLC

5335 US HWY 220
SUMMERFIELD, NC 27358
(336) 617-8478 www.barrier1.com
sales@barrier1.com

PATENT PROTECTED

THE DRAWINGS AND INFORMATION CONTAINED HEREIN ARE PROPRIETARY AND CONFIDENTIAL, AND ARE AUTHORIZED ONLY FOR USE FOR WORK ASSOCIATED WITH BARRIER1 SYSTEMS, LLC ALL RIGHTS RESERVED.

NET BARRIER
ENCLOSURE DETAIL
(1 OF 2)

VA-NET-300
WEBSITE DRAWING

SHEET: 13 OF 14

20241218-10-W

SCALE: N.T.S.

B1 PREDATOR M50

NET BASED VEHICLE ARRESTOR - MODEL VA-NET-300

CRASH TESTED TO ASTM F2656-07 - M50/P2 RATED - STOPS 15,000 LB. VEHICLE AT 50 MPH IMPACT

CONTROL AND STATIC SIDE END SUPPORT ENCLOSURES

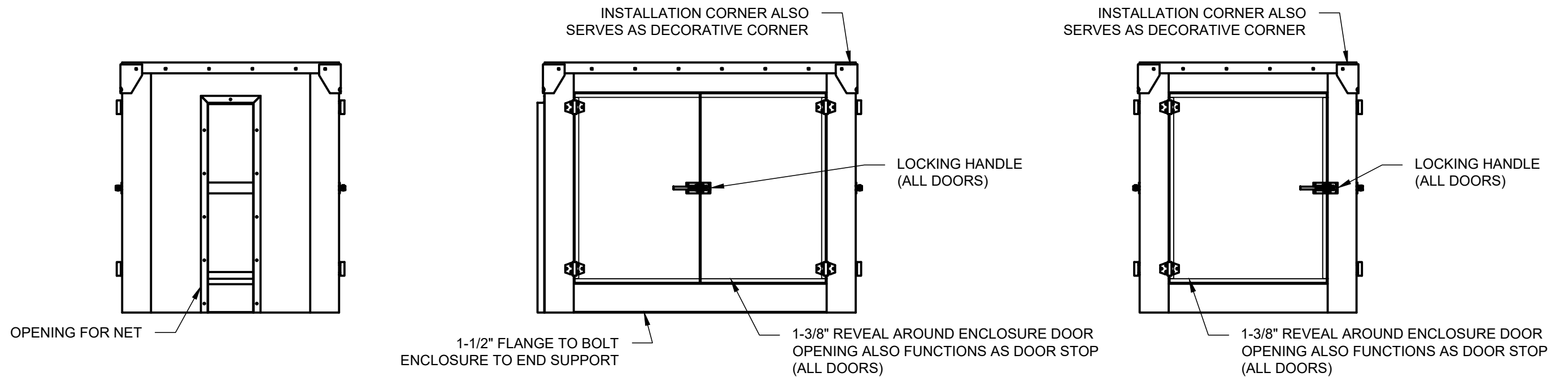

BARRIER1 SYSTEMS, LLC

5335 US HWY 220
SUMMERFIELD, NC 27358
(336) 617-8478 www.barrier1.com
sales@barrier1.com

PATENT PROTECTED

THE DRAWINGS AND INFORMATION CONTAINED HEREIN ARE PROPRIETARY AND CONFIDENTIAL, AND ARE AUTHORIZED ONLY FOR USE FOR WORK ASSOCIATED WITH BARRIER1 SYSTEMS, LLC ALL RIGHTS RESERVED.

NET BARRIER
ENCLOSURE DETAIL
(2 OF 2)

VA-NET-300
WEBSITE DRAWING

SHEET: 14 OF 14

20241218-10-W

SCALE: N.T.S.