

# B1 TOMCAT

TRAFFIC IMPACT BOLLARD - MODEL TIB-67-SA

UNOFFICIAL CRASH TEST STOPPED 2,430 LB. VEHICLE AT 40 MPH IMPACT WITHIN 3.3FT

## TYPICAL SINGLE BOLLARD INSTALLATION

**KEY FEATURES:**

1. PREFABRICATED BOLLARD UNIT
2. NO REBAR IN FOUNDATION
3. BOLLARD SYSTEM CAN ACCOMMODATE ANY TURNING RADIUS

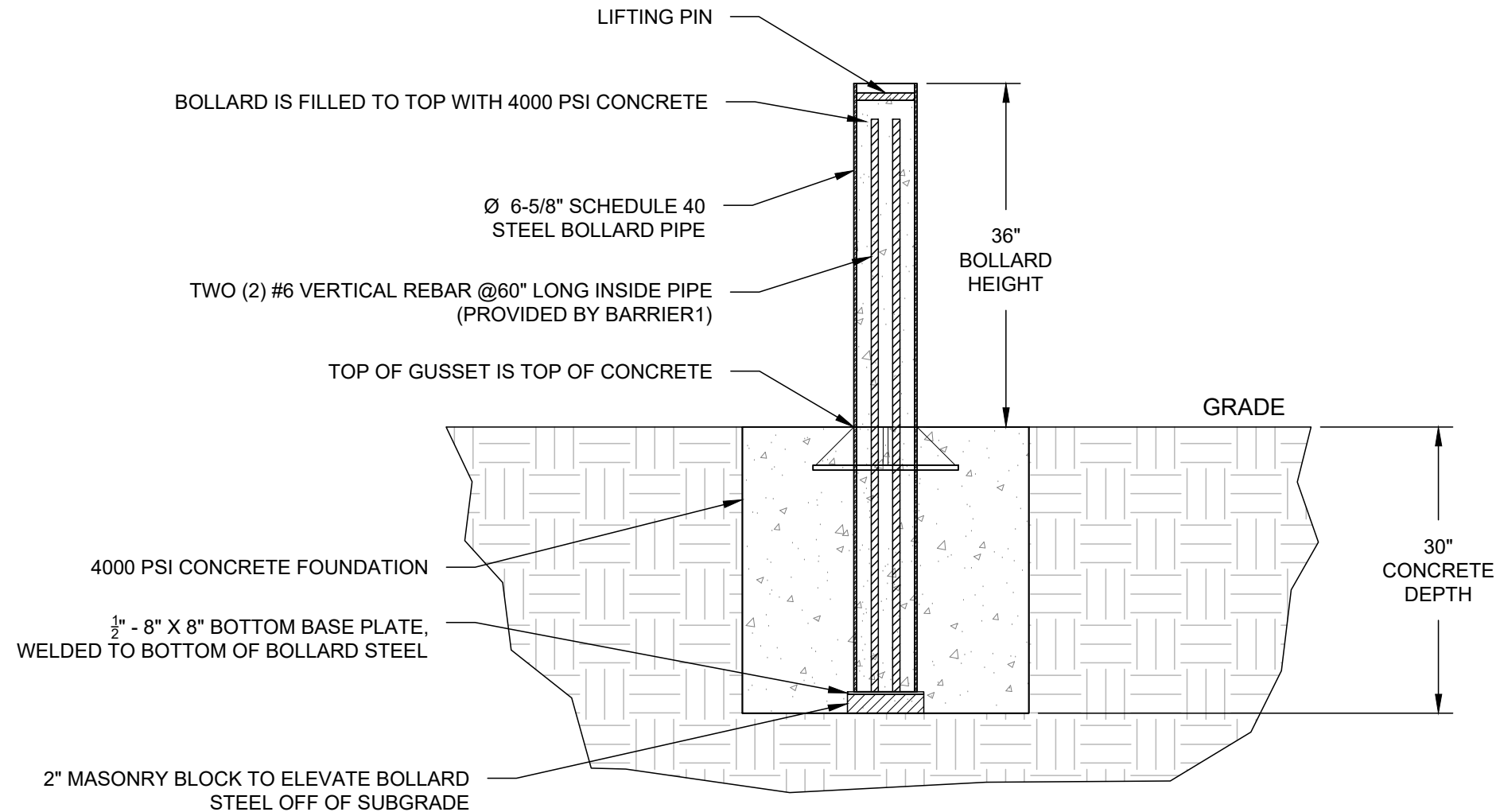

**NOTE:**  
TOTAL QUANTITY OF BOLLARDS PROVIDED TO BE LISTED ON PURCHASE ORDER.

PLEASE SIGN AND DATE BELOW TO ACKNOWLEDGE ACCEPTANCE OF THE SUBMITTAL DRAWING.

NAME:
SIGNATURE:
DATE:



**BARRIER1 SYSTEMS, LLC**

5335 US HWY 220  
SUMMERFIELD, NC 27358  
(336) 617-8478 www.barrier1.com  
sales@barrier1.com

**PATENT PROTECTED**

**THE DRAWINGS AND INFORMATION CONTAINED HEREIN ARE PROPRIETARY AND CONFIDENTIAL, AND ARE AUTHORIZED ONLY FOR USE FOR WORK ASSOCIATED WITH BARRIER1 SYSTEMS, LLC ALL RIGHTS RESERVED.**

ELEVATION VIEW  
(STAND-ALONE)

TIB-67-SA  
SUBMITTAL DRAWING

SHEET: 1 OF 6

20240830-10-S

SCALE: N.T.S.

# B1 TOMCAT

TRAFFIC IMPACT BOLLARD - MODEL TIB-67-SA

UNOFFICIAL CRASH TEST STOPPED 2,430 LB. VEHICLE AT 40 MPH IMPACT WITHIN 3.3FT

## TYPICAL SINGLE BOLLARD INSTALLATION

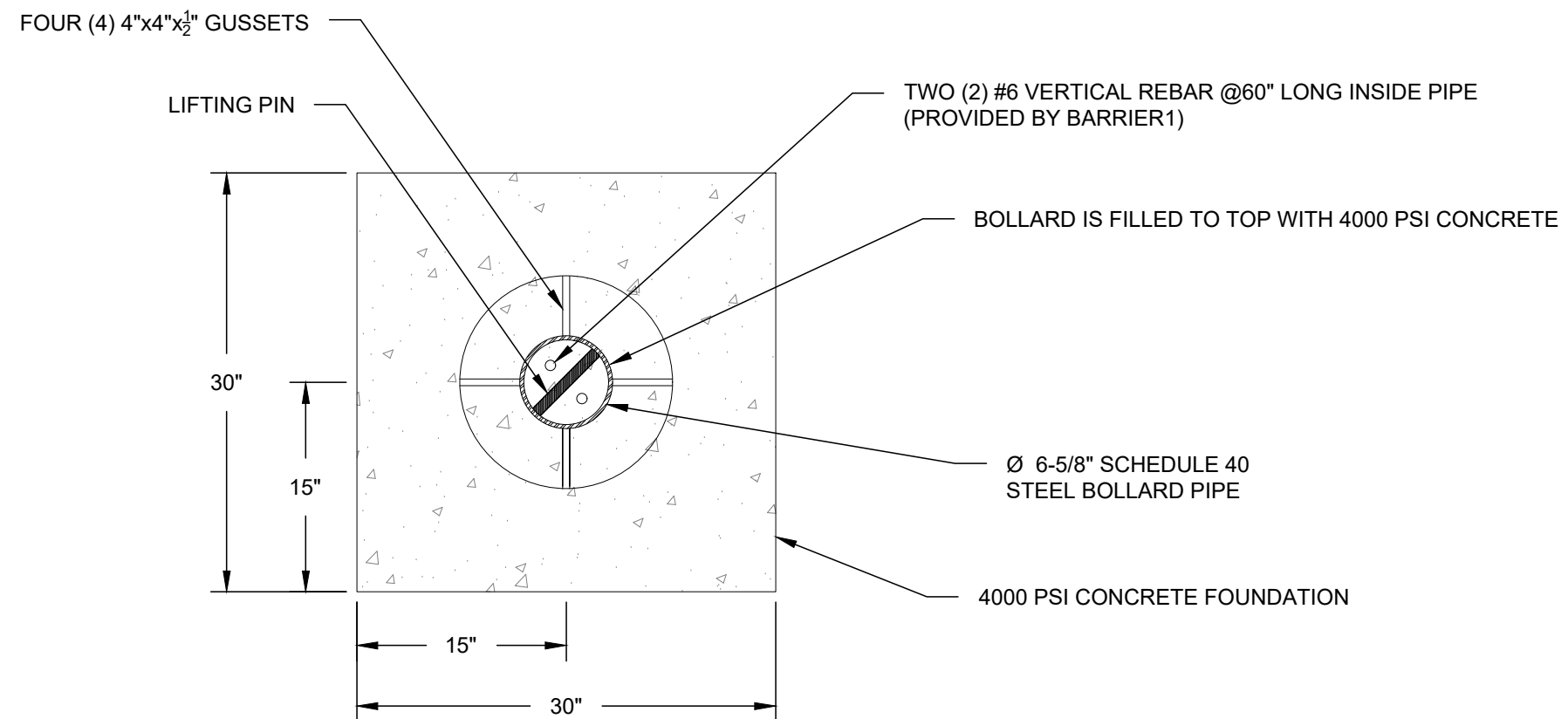

**BARRIER1 SYSTEMS, LLC**

5335 US HWY 220  
SUMMERFIELD, NC 27358  
(336) 617-8478 www.barrier1.com  
sales@barrier1.com

**PATENT PROTECTED**

**THE DRAWINGS AND INFORMATION CONTAINED HEREIN ARE PROPRIETARY AND CONFIDENTIAL, AND ARE AUTHORIZED ONLY FOR USE FOR WORK ASSOCIATED WITH BARRIER1 SYSTEMS, LLC ALL RIGHTS RESERVED.**

PLAN VIEW  
(STAND-ALONE)

TIB-67-SA  
SUBMITTAL DRAWING

SHEET: 2 OF 6

20240830-10-S

SCALE: N.T.S.

# B1 TOMCAT

TRAFFIC IMPACT BOLLARD - MODEL TIB-67-SA

UNOFFICIAL CRASH TEST STOPPED 2,430 LB. VEHICLE AT 40 MPH IMPACT WITHIN 3.3FT

## TYPICAL BOLLARD ARRAY INSTALLATION

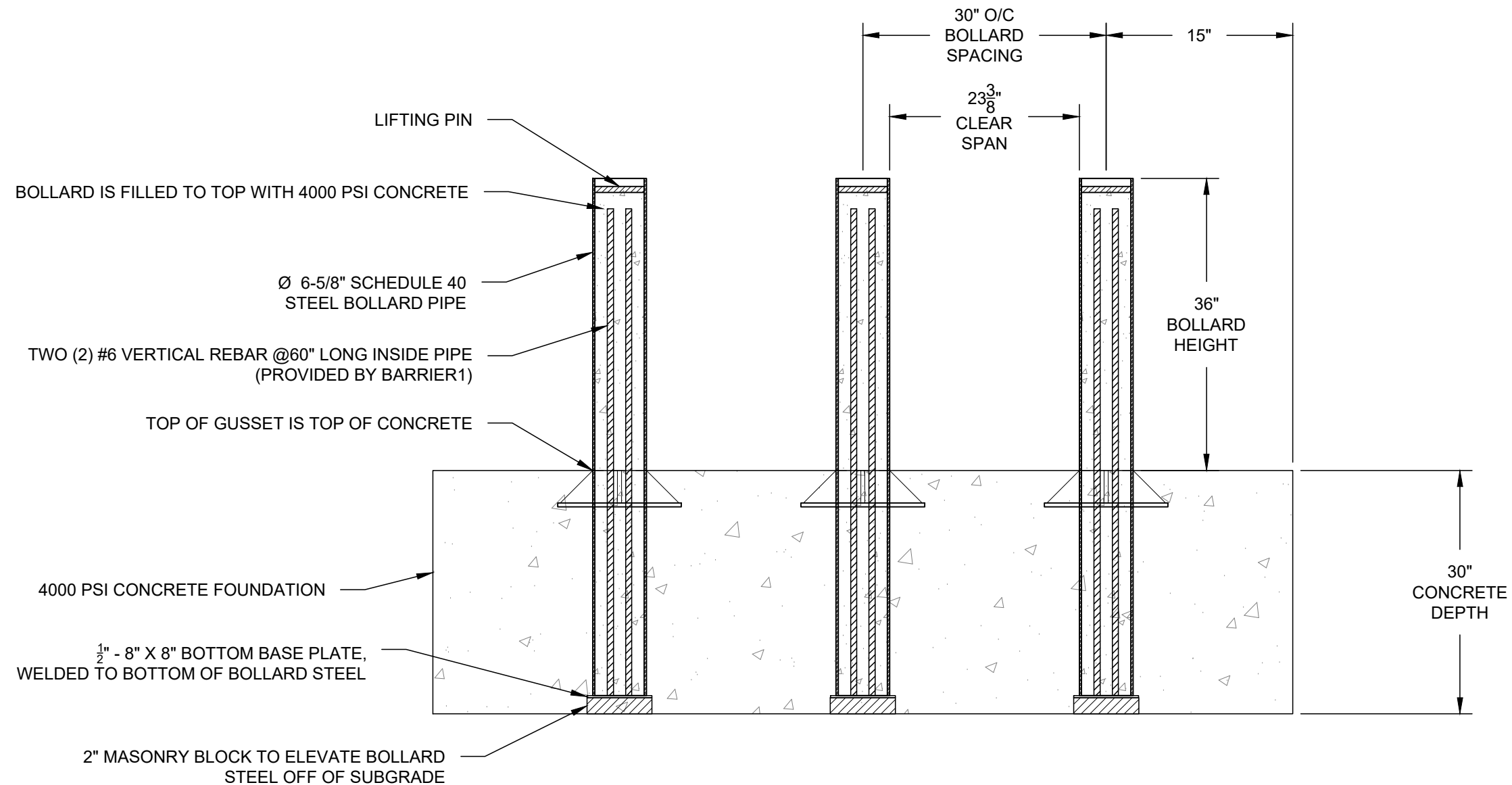

NOTE:

1. MODIFIED SPACING FOR SITE SPECIFIC CONDITIONS AVAILABLE.



**BARRIER1 SYSTEMS, LLC**

5335 US HWY 220  
 SUMMERFIELD, NC 27358  
 (336) 617-8478 www.barrier1.com  
 sales@barrier1.com

**PATENT PROTECTED**

**THE DRAWINGS AND INFORMATION CONTAINED HEREIN ARE PROPRIETARY AND CONFIDENTIAL, AND ARE AUTHORIZED ONLY FOR USE FOR WORK ASSOCIATED WITH BARRIER1 SYSTEMS, LLC ALL RIGHTS RESERVED.**

ELEVATION VIEW  
(ARRAY)

TIB-67-SA  
SUBMITTAL DRAWING

SHEET: 3 OF 6

20240830-10-S

SCALE: N.T.S.

# B1 TOMCAT

TRAFFIC IMPACT BOLLARD - MODEL TIB-67-SA

UNOFFICIAL CRASH TEST STOPPED 2,430 LB. VEHICLE AT 40 MPH IMPACT WITHIN 3.3FT

## TYPICAL BOLLARD ARRAY INSTALLATION

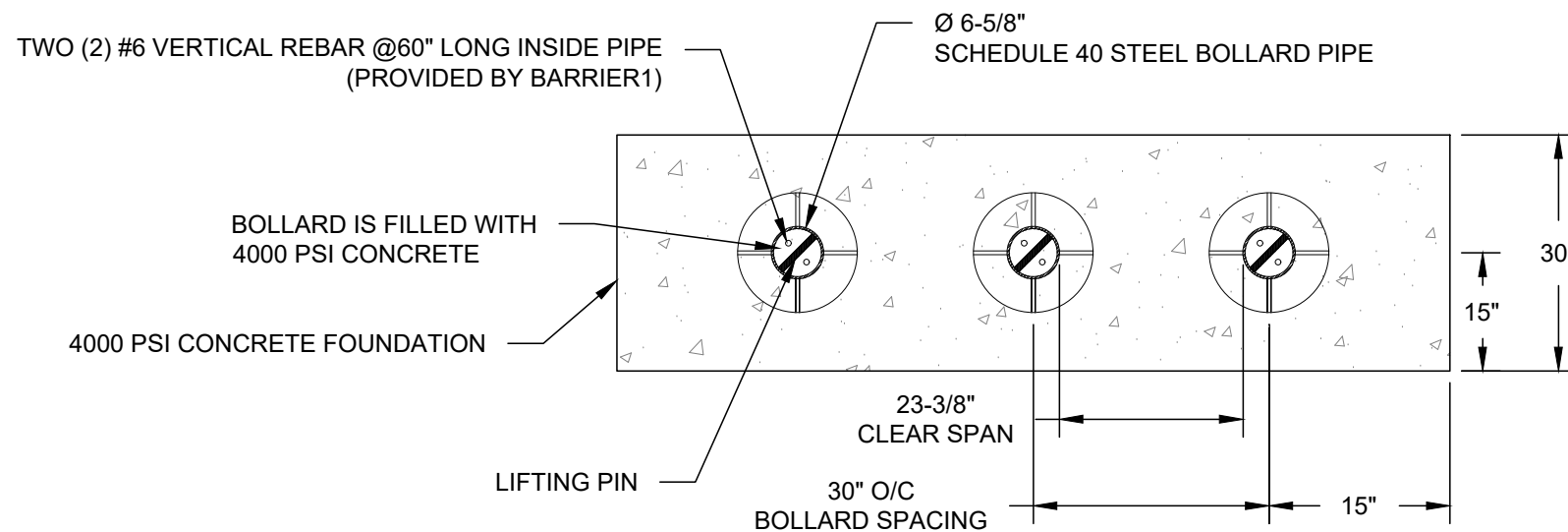

NOTE:

1. MODIFIED SPACING FOR SITE SPECIFIC CONDITIONS AVAILABLE.



### BARRIER1 SYSTEMS, LLC

5335 US HWY 220  
SUMMERFIELD, NC 27358  
(336) 617-8478 www.barrier1.com  
sales@barrier1.com

**PATENT PROTECTED**

**THE DRAWINGS AND INFORMATION CONTAINED HEREIN ARE PROPRIETARY AND CONFIDENTIAL, AND ARE AUTHORIZED ONLY FOR USE FOR WORK ASSOCIATED WITH BARRIER1 SYSTEMS, LLC ALL RIGHTS RESERVED.**

PLAN VIEW  
(ARRAY)

TIB-67-SA  
SUBMITTAL DRAWING

SHEET: 4 OF 6

20240830-10-S

SCALE: N.T.S.

# B1 TOMCAT

TRAFFIC IMPACT BOLLARD - MODEL TIB-67-SA

UNOFFICIAL CRASH TEST STOPPED 2,430 LB. VEHICLE AT 40 MPH IMPACT WITHIN 3.3FT

## MATERIALS PROVIDED

### PREFABRICATED BOLLARD MATERIALS PROVIDED BY BARRIER1 SYSTEMS

STANDARD FINISH:  
BLACK PAINT

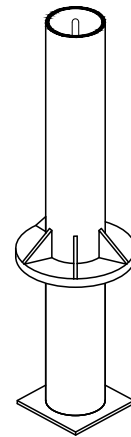

(QTY 1) EACH:  
BOLLARD ASSEMBLY



(QTY 2) EACH:  
PRE-CUT #6 VERTICAL REBAR  
@ 60" LONG  
(PLACED INSIDE BOLLARD)

### MATERIALS PROVIDED BY INSTALLER

1. CONCRETE, ABOUT 0.6 CUBIC YARDS PER BOLLARD
2. MASONRY BLOCKS OR CHAIRS TO ELEVATE BOLLARDS OFF OF SUBGRADE



### BARRIER1 SYSTEMS, LLC

5335 US HWY 220  
SUMMERFIELD, NC 27358  
(336) 617-8478 www.barrier1.com  
sales@barrier1.com

**PATENT PROTECTED**

**THE DRAWINGS AND INFORMATION CONTAINED HEREIN ARE PROPRIETARY AND CONFIDENTIAL, AND ARE AUTHORIZED ONLY FOR USE FOR WORK ASSOCIATED WITH BARRIER1 SYSTEMS, LLC ALL RIGHTS RESERVED.**

MATERIALS  
PROVIDED

TIB-67-SA  
SUBMITTAL DRAWING

SHEET: 5 OF 6

20240830-10-S

SCALE: N.T.S.

# B1 TOMCAT

TRAFFIC IMPACT BOLLARD - MODEL TIB-67-SA

UNOFFICIAL CRASH TEST STOPPED 2,430 LB. VEHICLE AT 40 MPH IMPACT WITHIN 3.3FT

## INSTALLATION STEPS

① EXCAVATE THEN TAMP SUBGRADE WITH PLATE TAMPER.

② USE MASONRY BLOCK OR CHAIRS TO ELEVATE BOLLARD OFF SUBGRADE, SO THAT TOP OF GUSSET / SLEEVE IS SAME HEIGHT AS TOP OF CONCRETE.

③ PLACE PREFABRICATED BOLLARDS INTO EXCAVATION.

④ INSERT VERTICAL REBAR INTO BOLLARD TUBE.

⑤ FILL BOLLARD TUBE AND EXCAVATION WITH CONCRETE.

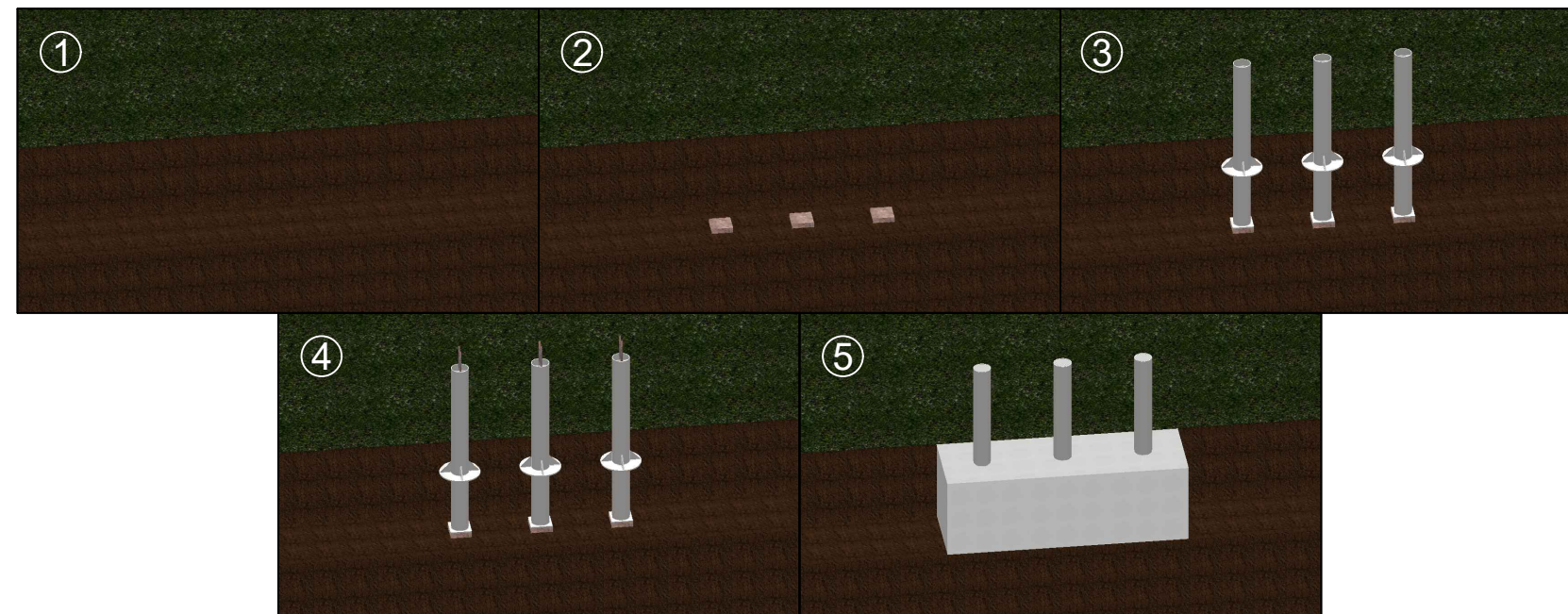

**BARRIER1 SYSTEMS, LLC**

5335 US HWY 220  
SUMMERFIELD, NC 27358  
(336) 617-8478 www.barrier1.com  
sales@barrier1.com

**PATENT PROTECTED**

**THE DRAWINGS AND INFORMATION CONTAINED HEREIN ARE PROPRIETARY AND CONFIDENTIAL, AND ARE AUTHORIZED ONLY FOR USE FOR WORK ASSOCIATED WITH BARRIER1 SYSTEMS, LLC ALL RIGHTS RESERVED.**

INSTALLATION STEPS

TIB-67-SA  
SUBMITTAL DRAWING

SHEET: 6 OF 6

20240830-10-S

SCALE: N.T.S.