

B1 TOMAHAWK M30

SHALLOW MOUNT BOLLARD - MODEL SMB-400-SSA

CRASH TESTED TO ASTM F2656-15 - M30/P1 RATED - STOPS 15,000 LB. VEHICLE AT 30 MPH IMPACT

TYPICAL SINGLE BOLLARD INSTALLATION

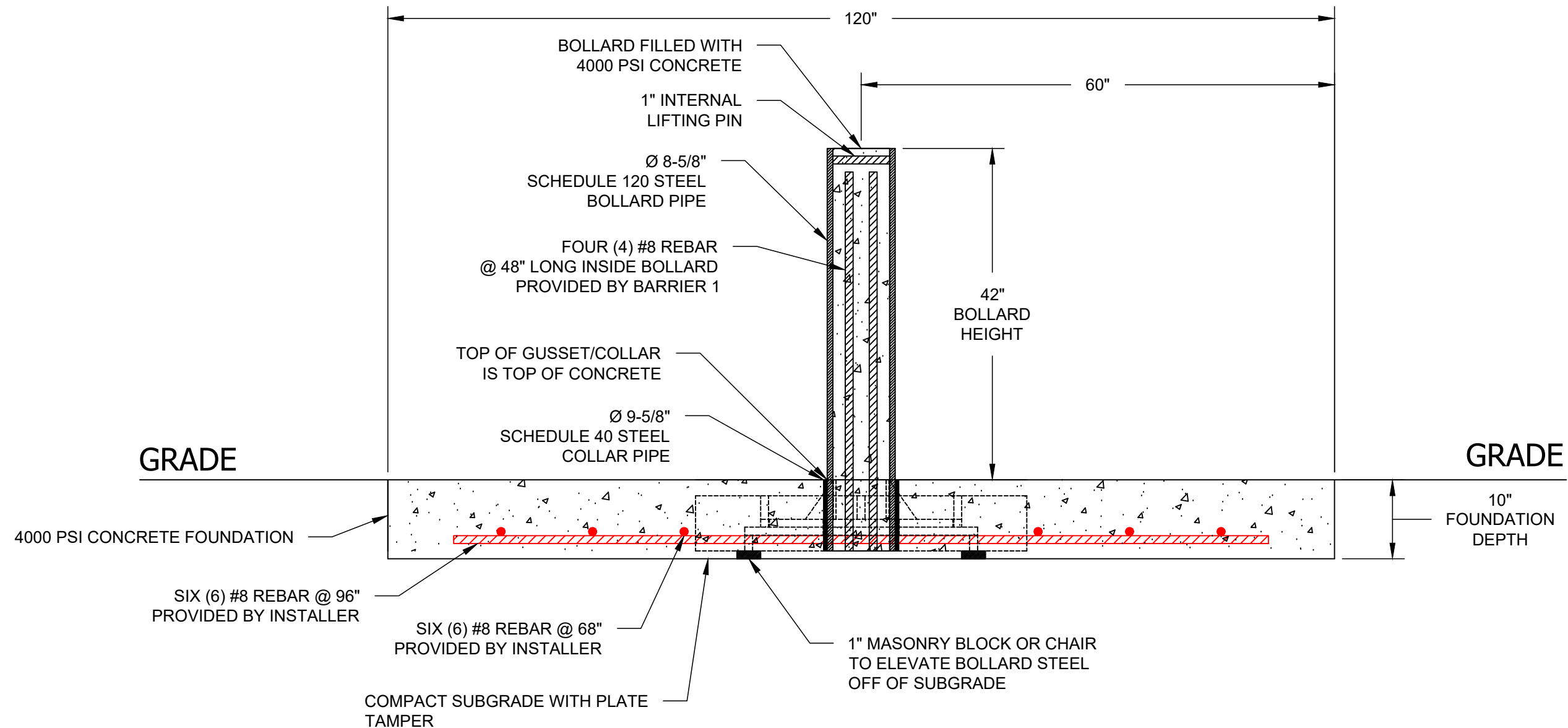

BARRIER1 SYSTEMS, LLC

5335 US HWY 220
SUMMERFIELD, NC 27358
(336) 617-8478 www.barrier1.com
sales@barrier1.com

PATENT PROTECTED

THE DRAWINGS AND INFORMATION CONTAINED HEREIN ARE PROPRIETARY AND CONFIDENTIAL, AND ARE AUTHORIZED ONLY FOR USE FOR WORK ASSOCIATED WITH BARRIER1 SYSTEMS, LLC ALL RIGHTS RESERVED.

ELEVATION VIEW
(STAND-ALONE)

SMB-400-SA
WEBSITE DRAWING

SHEET: 1 OF 6

20240522-10-M

SCALE: N.T.S.

B1 TOMAHAWK M30

SHALLOW MOUNT BOLLARD - MODEL SMB-400-SSA

CRASH TESTED TO ASTM F2656-15 - M30/P1 RATED - STOPS 15,000 LB. VEHICLE AT 30 MPH IMPACT

TYPICAL SINGLE BOLLARD INSTALLATION

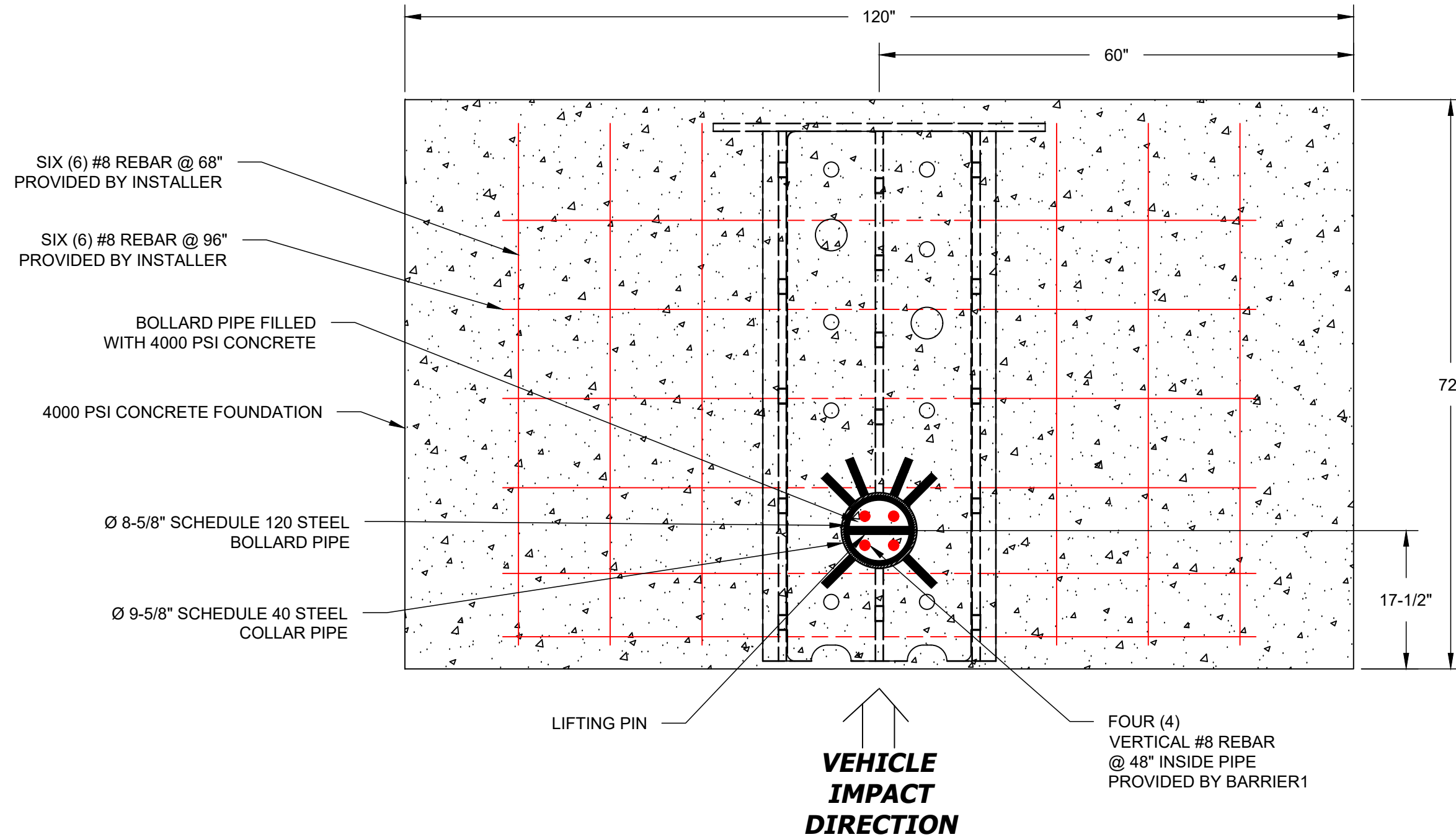

BARRIER1 SYSTEMS, LLC

5335 US HWY 220
SUMMERFIELD, NC 27358
(336) 617-8478 www.barrier1.com
sales@barrier1.com

PATENT PROTECTED

**THE DRAWINGS AND INFORMATION CONTAINED HEREIN ARE
PROPRIETARY AND CONFIDENTIAL, AND ARE AUTHORIZED ONLY
FOR USE FOR WORK ASSOCIATED WITH BARRIER1 SYSTEMS, LLC
ALL RIGHTS RESERVED.**

ELEVATION VIEW
(STAND-ALONE)

SMB-400-SA
WEBSITE DRAWING

SHEET: 2 OF 6

20240522-10-M

SCALE: N.T.S.

B1 TOMAHAWK M30

SHALLOW MOUNT BOLLARD - MODEL SMB-400-SSA

CRASH TESTED TO ASTM F2656-15 - M30/P1 RATED - STOPS 15,000 LB. VEHICLE AT 30 MPH IMPACT

TYPICAL BOLLARD ARRAY INSTALLATION

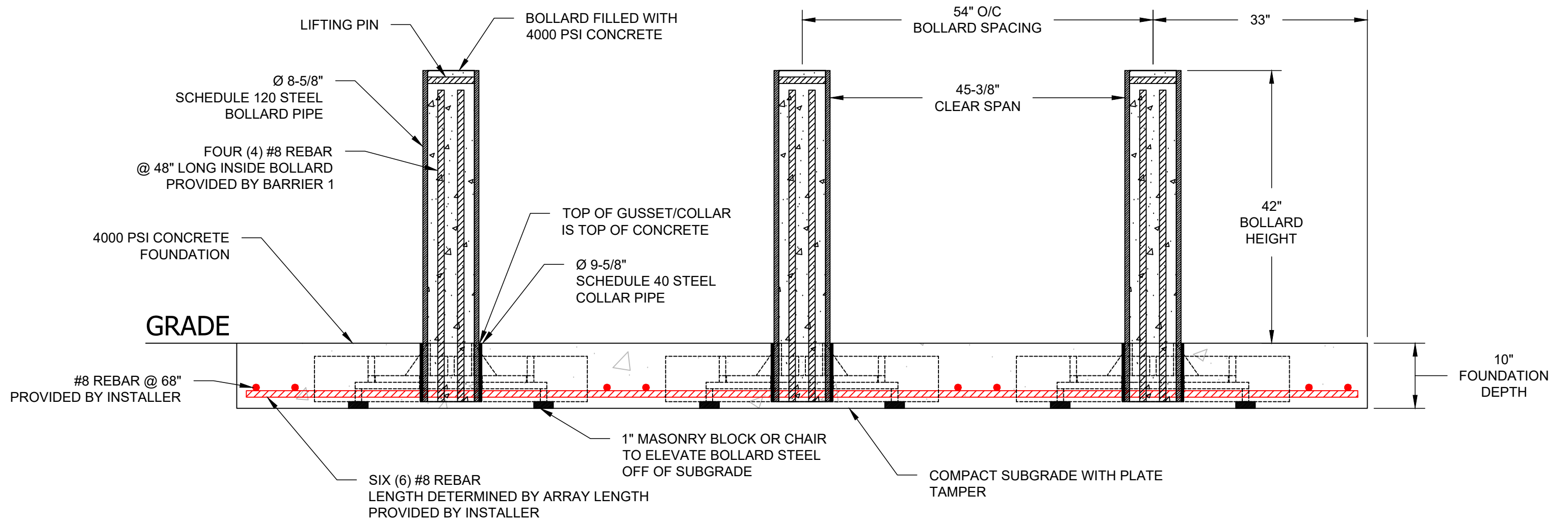

NOTE:

- 1. MODIFIED SPACING FOR SITE SPECIFIC CONDITIONS AVAILABLE



BARRIER1 SYSTEMS, LLC

5335 US HWY 220
SUMMERFIELD, NC 27358
(336) 617-8478 www.barrier1.com
sales@barrier1.com

PATENT PROTECTED

THE DRAWINGS AND INFORMATION CONTAINED HEREIN ARE PROPRIETARY AND CONFIDENTIAL, AND ARE AUTHORIZED ONLY FOR USE FOR WORK ASSOCIATED WITH BARRIER1 SYSTEMS, LLC ALL RIGHTS RESERVED.

ELEVATION VIEW
(ARRAY - MODIFIED)

SMB-400-SA
WEBSITE DRAWING

SHEET: 3 OF 6

20240522-10-M

SCALE: N.T.S.

B1 TOMAHAWK M30

SHALLOW MOUNT BOLLARD - MODEL SMB-400-SSA

CRASH TESTED TO ASTM F2656-15 - M30/P1 RATED - STOPS 15,000 LB. VEHICLE AT 30 MPH IMPACT

TYPICAL BOLLARD ARRAY INSTALLATION

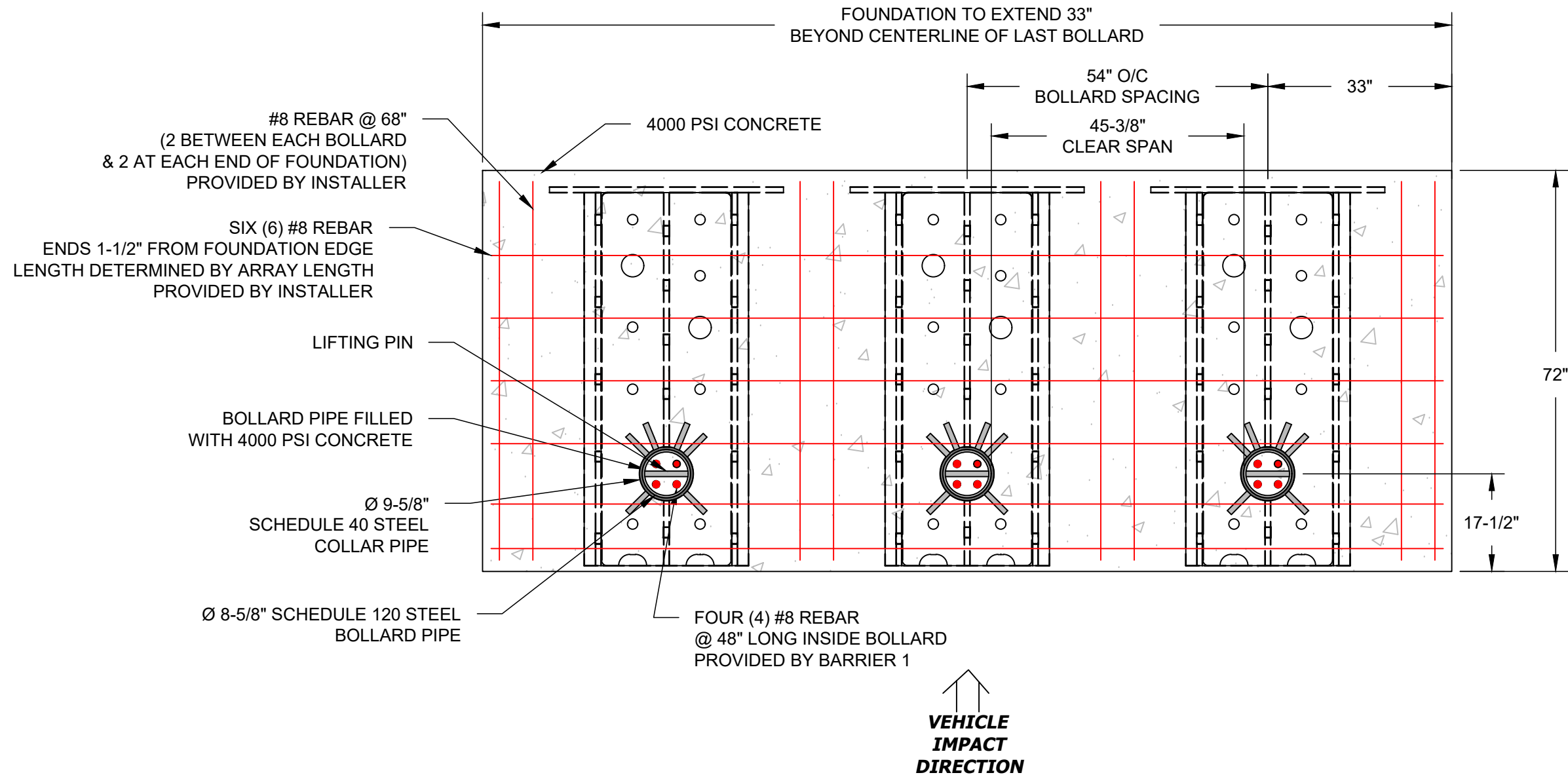

NOTE:

1. MODIFIED SPACING FOR SITE SPECIFIC CONDITIONS AVAILABLE



BARRIER1 SYSTEMS, LLC

5335 US HWY 220
 SUMMERFIELD, NC 27358
 (336) 617-8478 www.barrier1.com
 sales@barrier1.com

PATENT PROTECTED

THE DRAWINGS AND INFORMATION CONTAINED HEREIN ARE PROPRIETARY AND CONFIDENTIAL, AND ARE AUTHORIZED ONLY FOR USE FOR WORK ASSOCIATED WITH BARRIER1 SYSTEMS, LLC ALL RIGHTS RESERVED.

PLAN VIEW
 (ARRAY)

SMB-400-SA
 WEBSITE DRAWING

SHEET: 4 OF 6

20240522-10-M

SCALE: N.T.S.

B1 TOMAHAWK M30

SHALLOW MOUNT BOLLARD - MODEL SMB-400-SSA

CRASH TESTED TO ASTM F2656-15 - M30/P1 RATED - STOPS 15,000 LB. VEHICLE AT 30 MPH IMPACT

MATERIALS PROVIDED

MATERIALS PROVIDED BY BARRIER1 SYSTEMS

STANDARD FINISH:
BLACK PAINT

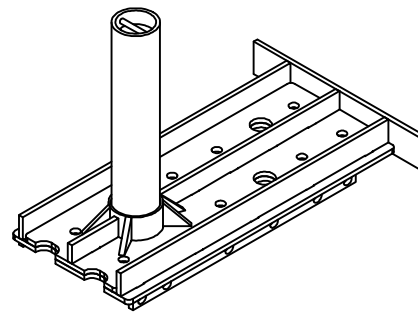

(1) EACH:
PREFABRICATED BOLLARD

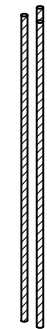

(4) EACH:
#8 VERTICAL REBAR
@ 48"

MATERIALS PROVIDED BY INSTALLER:

1. ABOUT 1.0 CUBIC YARDS OF CONCRETE PER BOLLARD FOR ARRAY
ABOUT 2.0 CUBIC YARDS OF CONCRETE PER BOLLARD FOR STANDALONE
2. SIX (6) #8 HORIZONTAL REBAR @96" PER BOLLARD OR BY ARRAY LENGTH TO
CONNECT ADJACENT BOLLARDS
3. #8 HORIZONTAL REBAR @68" LAID OVER #8 @ 96" REBAR BETWEEN ADJACENT
BOLLARDS AND EDGE OF FOUNDATION
4. MASONRY BRICKS OR CHAIRS TO ELEVATE BOLLARD STEEL OFF SUBGRADE



BARRIER1 SYSTEMS, LLC

5335 US HWY 220
SUMMERFIELD, NC 27358
(336) 617-8478 www.barrier1.com
sales@barrier1.com

PATENT PROTECTED

**THE DRAWINGS AND INFORMATION CONTAINED HEREIN ARE
PROPRIETARY AND CONFIDENTIAL, AND ARE AUTHORIZED ONLY
FOR USE FOR WORK ASSOCIATED WITH BARRIER1 SYSTEMS, LLC
ALL RIGHTS RESERVED.**

MATERIALS
PROVIDED

SMB-400-SA
WEBSITE DRAWING

SHEET: 5 OF 6

20240522-10-M

SCALE: N.T.S.

B1 TOMAHAWK M30

SHALLOW MOUNT BOLLARD - MODEL SMB-400-SSA

CRASH TESTED TO ASTM F2656-15 - M30/P1 RATED - STOPS 15,000 LB. VEHICLE AT 30 MPH IMPACT

INSTALLATION STEPS

① EXCAVATE THEN TAMP SUBGRADE WITH PLATE TAMPER.

② USE MASONRY BLOCK OR CHAIRS TO ELEVATE BOLLARD OFF SUBGRADE, SO THAT TOP OF GUSSET / SLEEVE IS SAME HEIGHT AS TOP OF CONCRETE.

③ PLACE PREFABRICATED BOLLARDS INTO EXCAVATION.

④ INSERT VERTICAL REBAR INTO BOLLARD TUBE.

⑤ INSERT #8 REBAR THROUGH PREFABRICATED HOLES TO CONNECT BOLLARDS.

⑥ POUR AND VIBRATE CONCRETE IN BOLLARD TUBE AND EXCAVATION

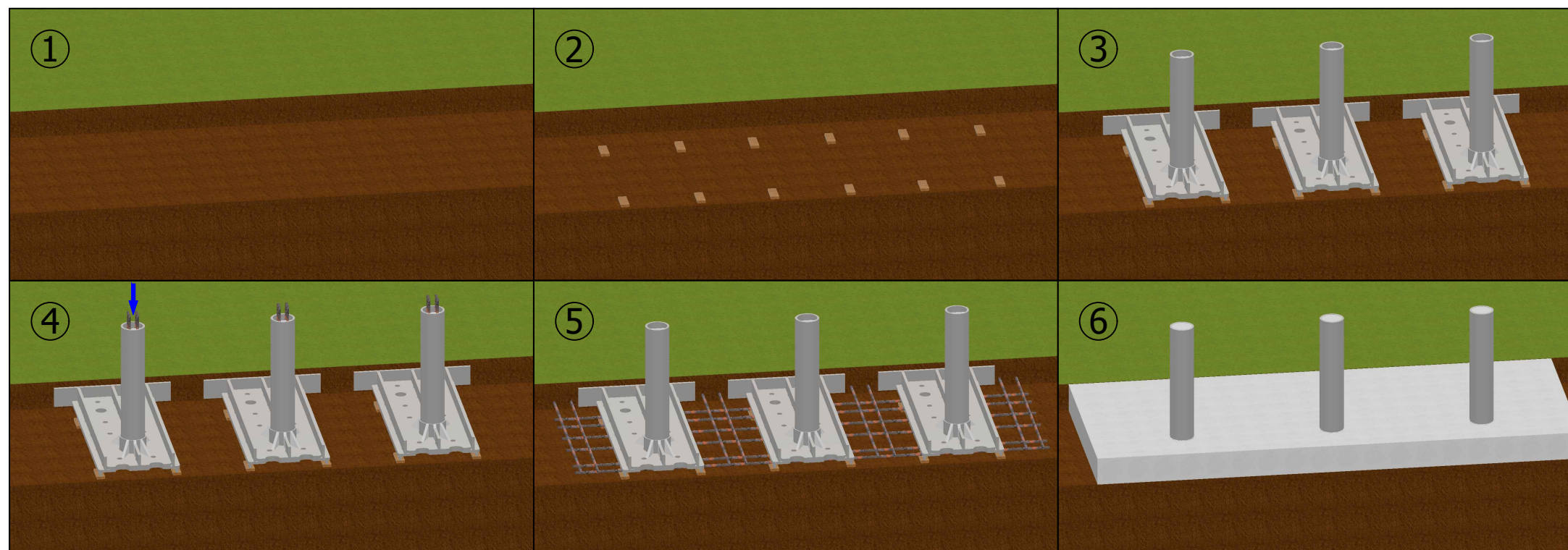

BARRIER1 SYSTEMS, LLC

5335 US HWY 220
SUMMERFIELD, NC 27358
(336) 617-8478 www.barrier1.com
sales@barrier1.com

PATENT PROTECTED

THE DRAWINGS AND INFORMATION CONTAINED HEREIN ARE PROPRIETARY AND CONFIDENTIAL, AND ARE AUTHORIZED ONLY FOR USE FOR WORK ASSOCIATED WITH BARRIER1 SYSTEMS, LLC ALL RIGHTS RESERVED.

INSTALLATION STEPS

SMB-400-SA
WEBSITE DRAWING

SHEET: 6 OF 6

20240522-10-M

SCALE: N.T.S.