

B1 NIMITZ M50

HORIZONTAL CRASH BEAM - MODEL HCB-ELE-1200

CRASH TESTED TO ASTM F2656-07 - M50/P2 RATED - STOPS 15,000 LB. VEHICLE AT 50 MPH IMPACT

CRASH BEAM ELEVATION VIEW

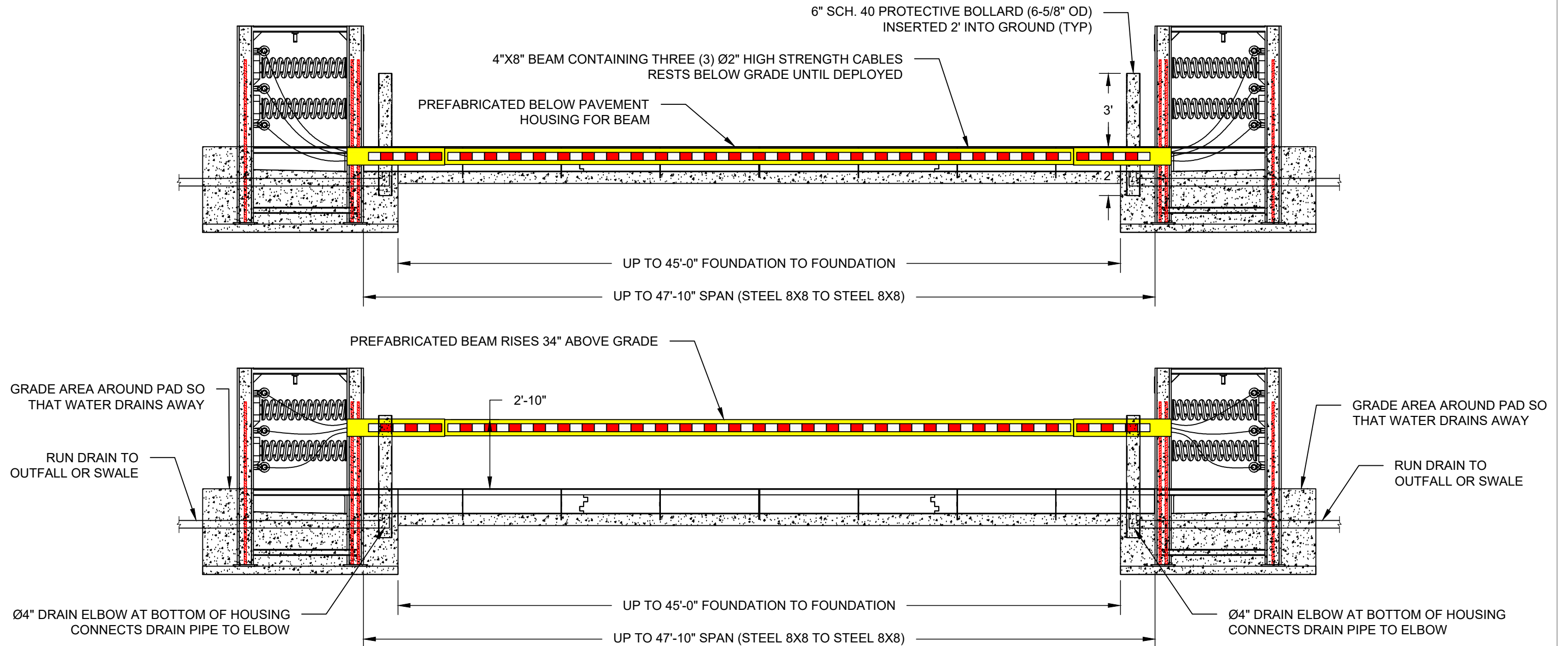

NOTE:

1. BARRIER LENGTH IS APPROXIMATE. CONFIRM SPACING ON ACTUAL SITE.



BARRIER1 SYSTEMS, LLC

5335 US HWY 220
SUMMERFIELD, NC 27358
(336) 617-8478 www.barrier1.com
sales@barrier1.com

PATENT PROTECTED

THE DRAWINGS AND INFORMATION CONTAINED HEREIN ARE PROPRIETARY AND CONFIDENTIAL, AND ARE AUTHORIZED ONLY FOR USE FOR WORK ASSOCIATED WITH BARRIER1 SYSTEMS, LLC ALL RIGHTS RESERVED.

HORIZONTAL CRASH BEAM
ELEVATION VIEW AND DETAIL
(1 OF 2)

HCB-ELE-1200
WEBSITE DRAWING

SHEET: 1 OF 12

20240718-10-M

SCALE: N.T.S.

B1 NIMITZ M50

HORIZONTAL CRASH BEAM - MODEL HCB-ELE-1200

CRASH TESTED TO ASTM F2656-07 - M50/P2 RATED - STOPS 15,000 LB. VEHICLE AT 50 MPH IMPACT

CRASH BEAM ELEVATION VIEW

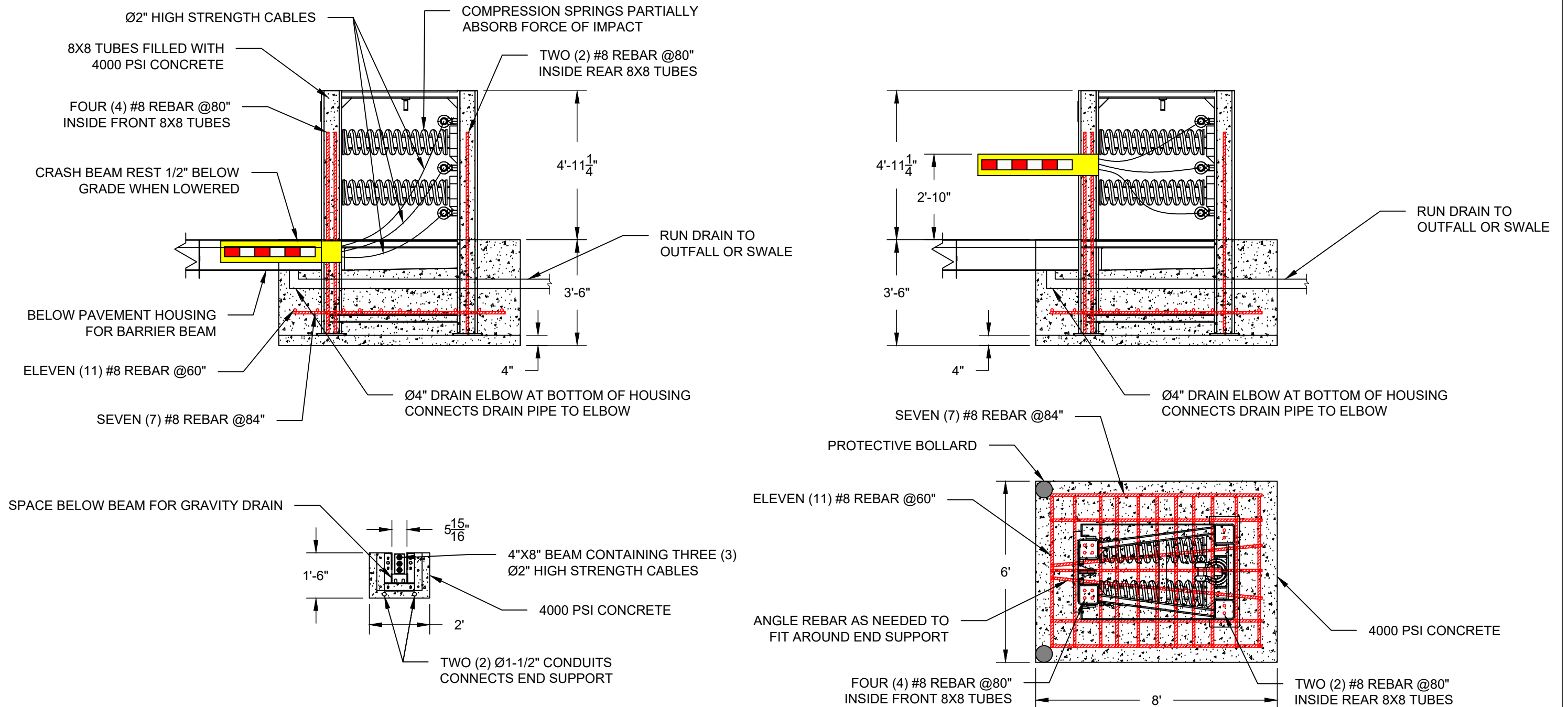

BARRIER1 SYSTEMS, LLC

5335 US HWY 220
 SUMMERFIELD, NC 27358
 (336) 617-8478 www.barrier1.com
 sales@barrier1.com

PATENT PROTECTED

THE DRAWINGS AND INFORMATION CONTAINED HEREIN ARE PROPRIETARY AND CONFIDENTIAL, AND ARE AUTHORIZED ONLY FOR USE FOR WORK ASSOCIATED WITH BARRIER1 SYSTEMS, LLC ALL RIGHTS RESERVED.

HORIZONTAL CRASH BEAM
 ELEVATION VIEW AND DETAIL
 (2 OF 2)

HCB-ELE-1200
 WEBSITE DRAWING

SHEET: 2 OF 12

20240718-10-M

SCALE: N.T.S.

B1 NIMITZ M50

HORIZONTAL CRASH BEAM - MODEL HCB-ELE-1200

CRASH TESTED TO ASTM F2656-07 - M50/P2 RATED - STOPS 15,000 LB. VEHICLE AT 50 MPH IMPACT

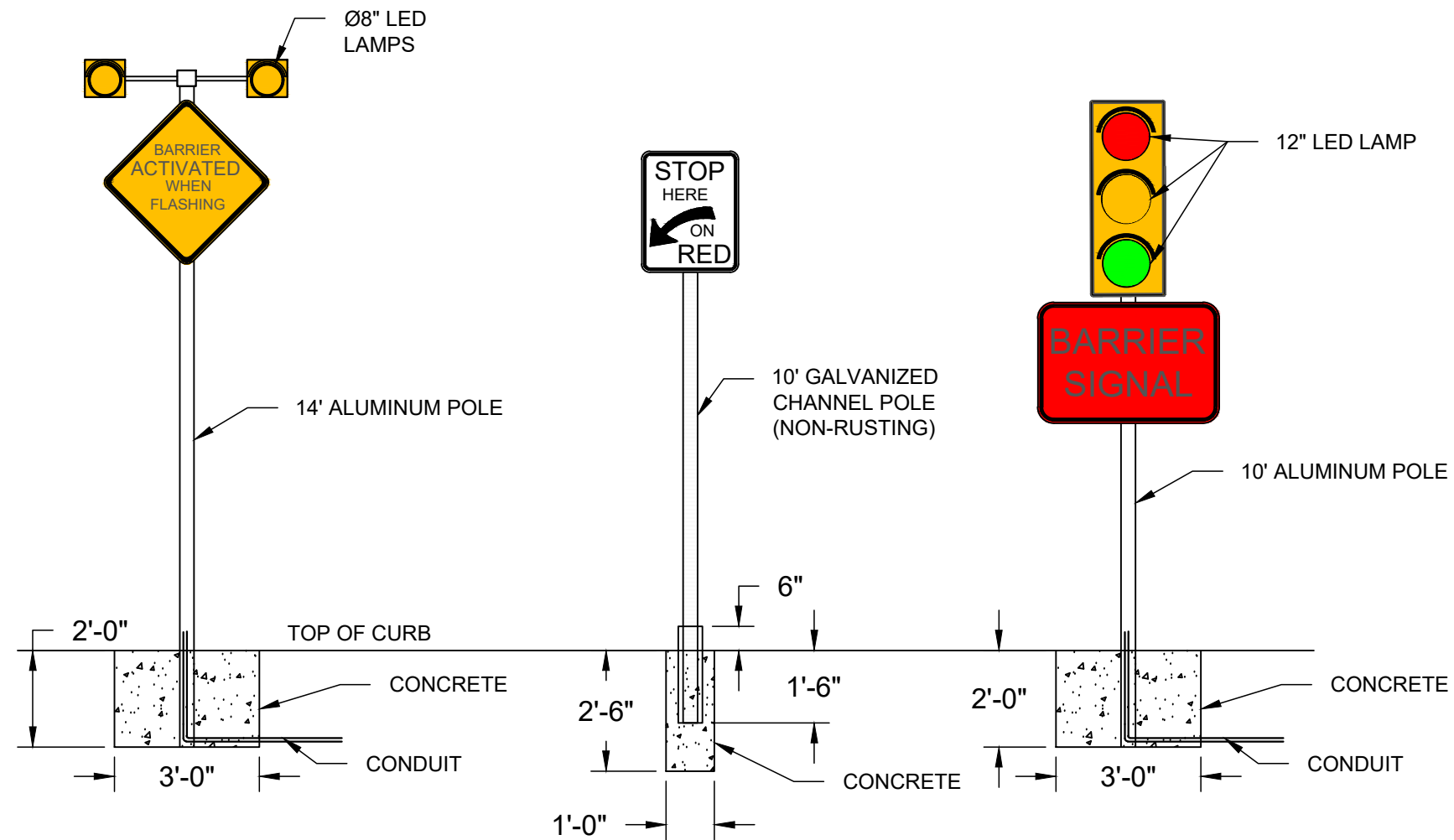

BARRIER1 SYSTEMS, LLC

5335 US HWY 220
 SUMMERFIELD, NC 27358
 (336) 617-8478 www.barrier1.com
 sales@barrier1.com

PATENT PROTECTED

THE DRAWINGS AND INFORMATION CONTAINED HEREIN ARE PROPRIETARY AND CONFIDENTIAL, AND ARE AUTHORIZED ONLY FOR USE FOR WORK ASSOCIATED WITH BARRIER1 SYSTEMS, LLC ALL RIGHTS RESERVED.

SIGNS AND SIGNAL
 ELEVATIONS

HCB-ELE-1200
 WEBSITE DRAWING

SHEET: 3 OF 12

20240718-10-M

SCALE: N.T.S.

B1 NIMITZ M50

HORIZONTAL CRASH BEAM - MODEL HCB-ELE-1200

CRASH TESTED TO ASTM F2656-07 - M50/P2 RATED - STOPS 15,000 LB. VEHICLE AT 50 MPH IMPACT

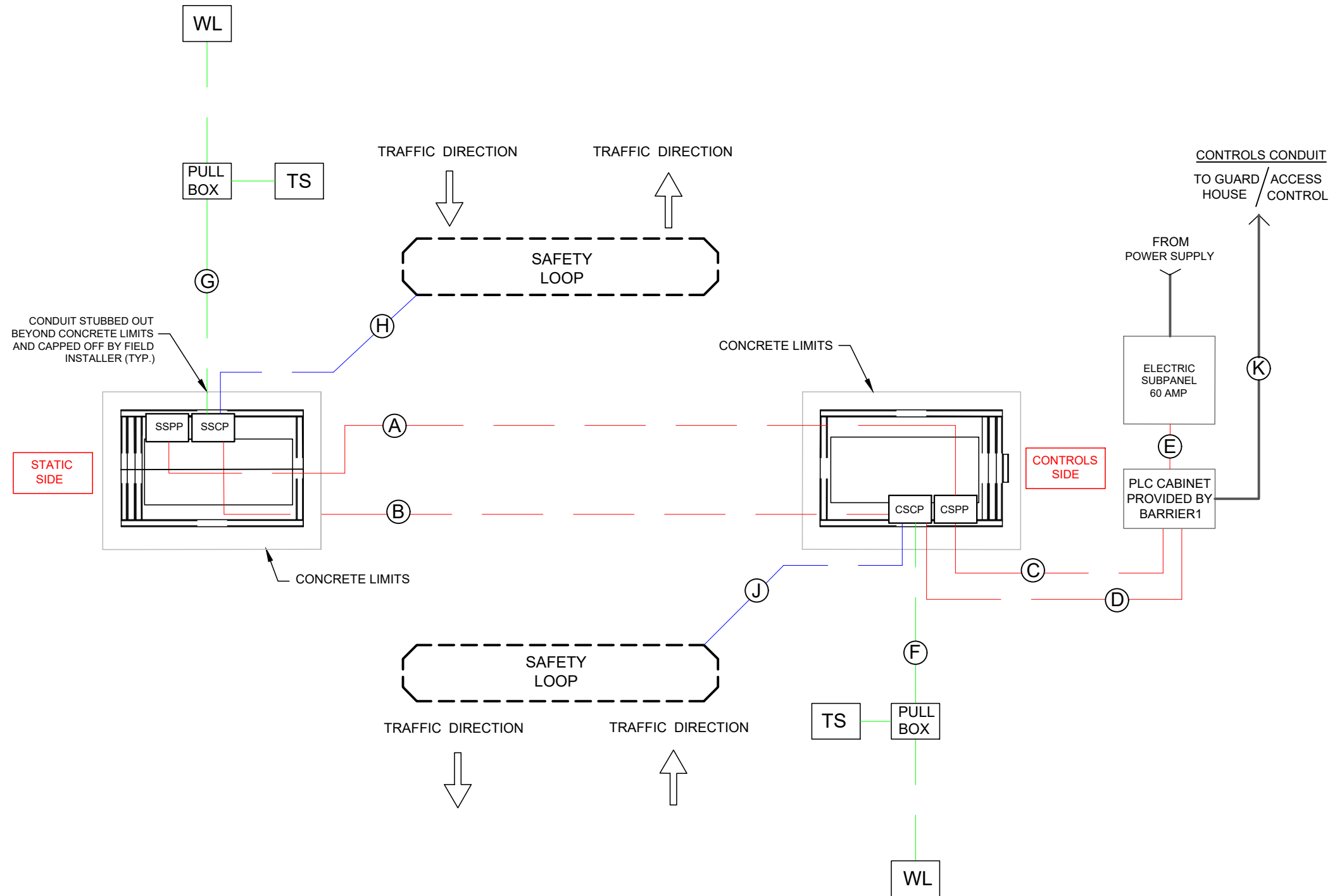

CONDUIT SCHEDULE

CONDUIT LABEL	CONDUIT DIAMETER	WIRE
(A)	1 1/2"	FOUR (4) 120VAC/20A CIRCUITS
(B)	1 1/2"	6 STRAND MULTI-MODE FIBER
(C)	1 1/2"	6 STRAND MULTI-MODE FIBER
(D)	1 1/2"	18 GAUGE, 25 CONDUCTOR
(E)	1 1/2"	TWO (2) 120VAC/20A CIRCUITS
(F)	1"	14 GAUGE, XHHW,
(G)	1"	14 GAUGE, XHHW,
(H)	1"	18 GAUGE, 3 CONDUCTOR
(I)	1"	18 GAUGE, 4 CONDUCTOR
(J)	1"	18 GAUGE, 3 CONDUCTOR
(K)	1"	18 GAUGE, 4 CONDUCTOR

SYMBOLS	SYMBOL KEY
WL	WARNING LIGHTS
O/W	OVERWATCH PANEL
SSP	CONTROLS PANEL, IN STATIC SIDE END SUPPORT
CSPP	POWER PANEL, IN CONTROLS SIDE END SUPPORT
CSCP	CONTROLS PANEL, IN CONTROLS SIDE END SUPPORT
TS	TRAFFIC SIGNAL



BARRIER1 SYSTEMS, LLC

5335 US HWY 220
 SUMMERFIELD, NC 27358
 (336) 617-8478 www.barrier1.com
 sales@barrier1.com

PATENT PROTECTED

THE DRAWINGS AND INFORMATION CONTAINED HEREIN ARE PROPRIETARY AND CONFIDENTIAL, AND ARE AUTHORIZED ONLY FOR USE FOR WORK ASSOCIATED WITH BARRIER1 SYSTEMS, LLC ALL RIGHTS RESERVED.

CONDUIT LAYOUT

HCB-ELE-1200
 WEBSITE DRAWING

SHEET: 4 OF 12

20240718-10-M

SCALE: N.T.S.

B1 NIMITZ M50

HORIZONTAL CRASH BEAM - MODEL HCB-ELE-1200

CRASH TESTED TO ASTM F2656-07 - M50/P2 RATED - STOPS 15,000 LB. VEHICLE AT 50 MPH IMPACT

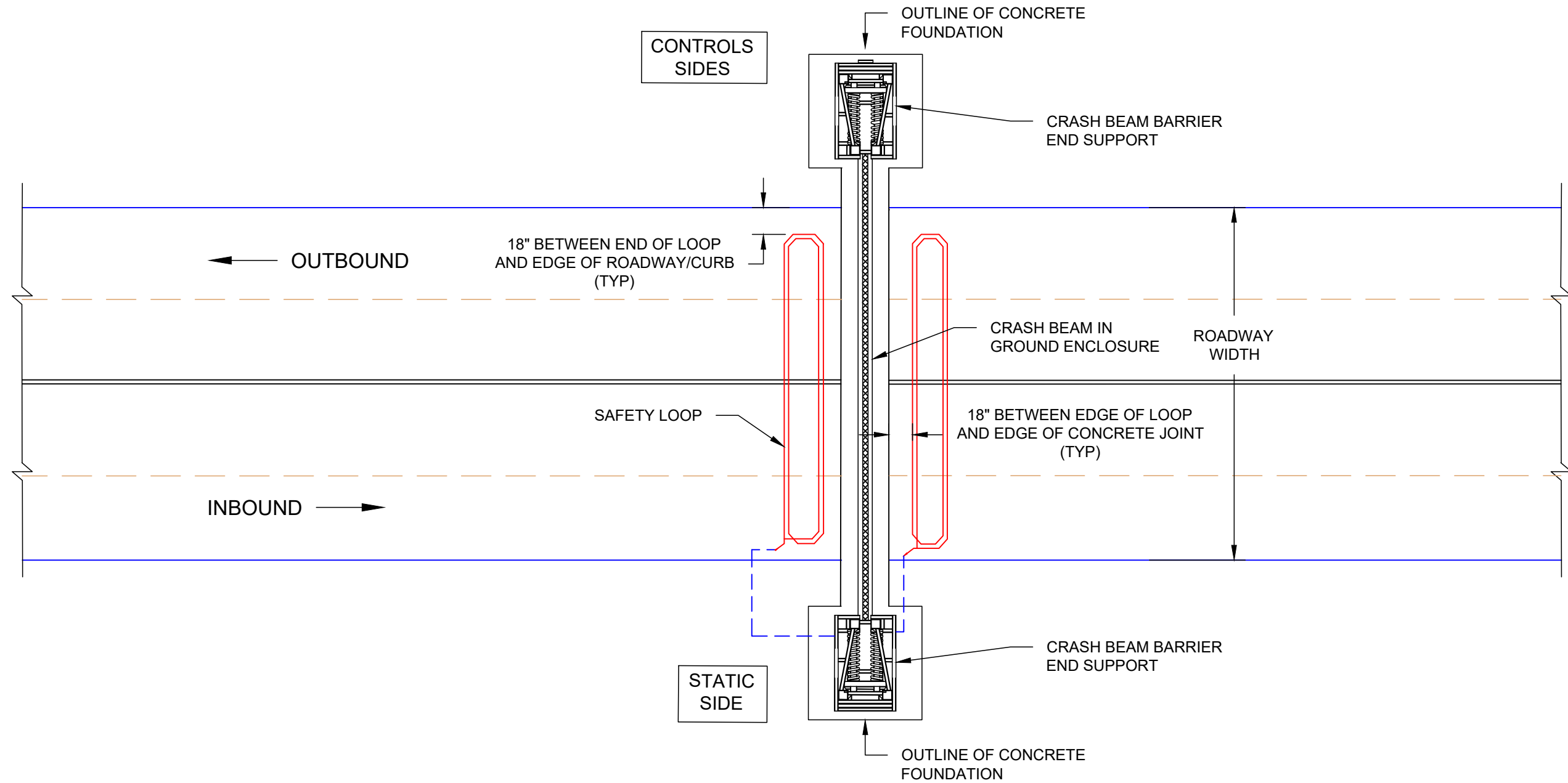

BARRIER1 SYSTEMS, LLC

5335 US HWY 220
SUMMERFIELD, NC 27358
(336) 617-8478 www.barrier1.com
sales@barrier1.com

PATENT PROTECTED

THE DRAWINGS AND INFORMATION CONTAINED HEREIN ARE PROPRIETARY AND CONFIDENTIAL, AND ARE AUTHORIZED ONLY FOR USE FOR WORK ASSOCIATED WITH BARRIER1 SYSTEMS, LLC ALL RIGHTS RESERVED.

SAFETY LOOP DETAIL

HCB-ELE-1200
WEBSITE DRAWING

SHEET: 5 OF 12

20240718-10-M

SCALE: N.T.S.

B1 NIMITZ M50

HORIZONTAL CRASH BEAM - MODEL HCB-ELE-1200

CRASH TESTED TO ASTM F2656-07 - M50/P2 RATED - STOPS 15,000 LB. VEHICLE AT 50 MPH IMPACT

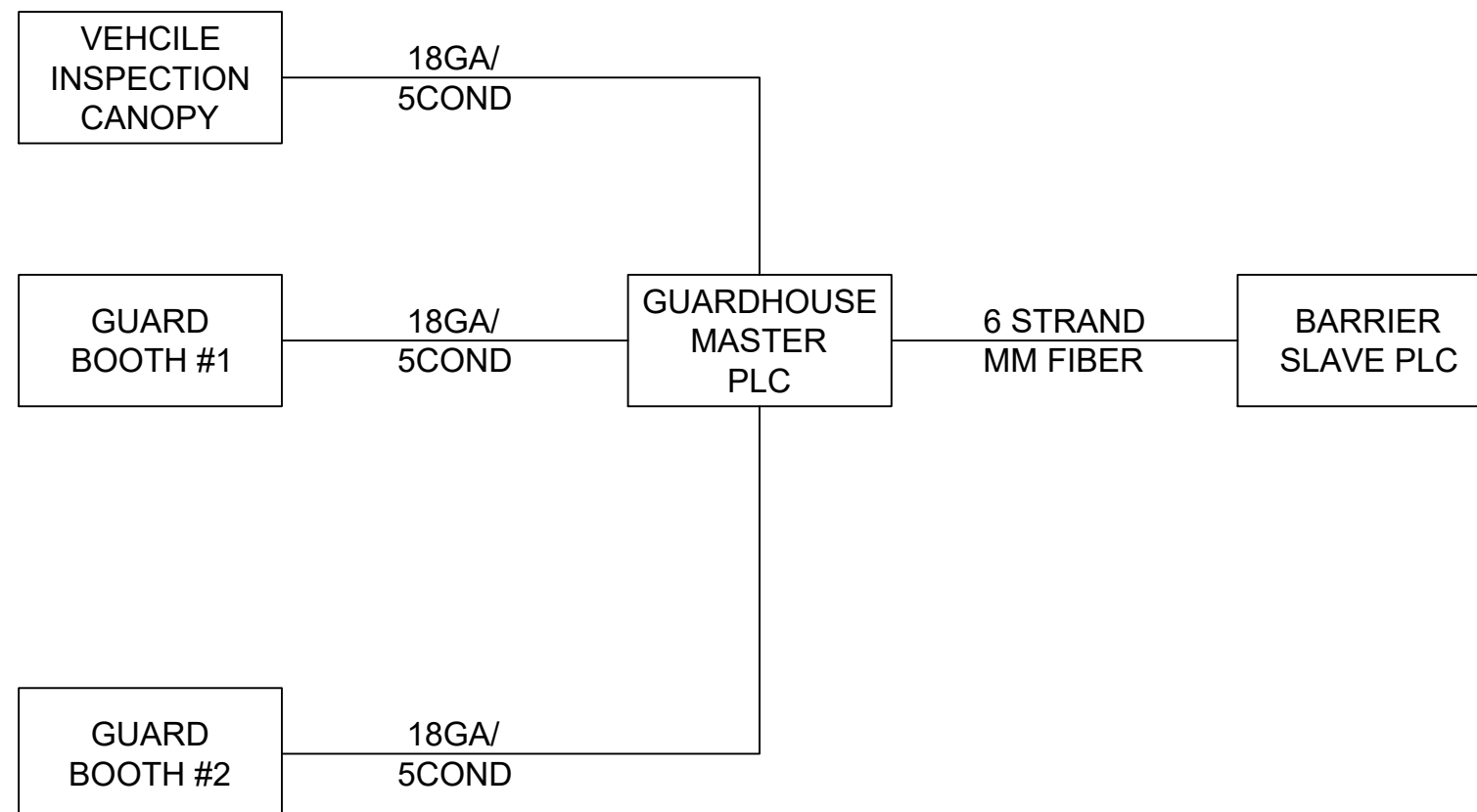

BARRIER1 SYSTEMS, LLC

5335 US HWY 220
SUMMERFIELD, NC 27358
(336) 617-8478 www.barrier1.com
sales@barrier1.com

PATENT PROTECTED

THE DRAWINGS AND INFORMATION CONTAINED HEREIN ARE PROPRIETARY AND CONFIDENTIAL, AND ARE AUTHORIZED ONLY FOR USE FOR WORK ASSOCIATED WITH BARRIER1 SYSTEMS, LLC ALL RIGHTS RESERVED.

SITE COMMUNICATION CABLING

HCB-ELE-1200
WEBSITE DRAWING

SHEET: 6 OF 12

20240718-10-M

SCALE: N.T.S.

B1 NIMITZ M50

HORIZONTAL CRASH BEAM - MODEL HCB-ELE-1200

CRASH TESTED TO ASTM F2656-07 - M50/P2 RATED - STOPS 15,000 LB. VEHICLE AT 50 MPH IMPACT

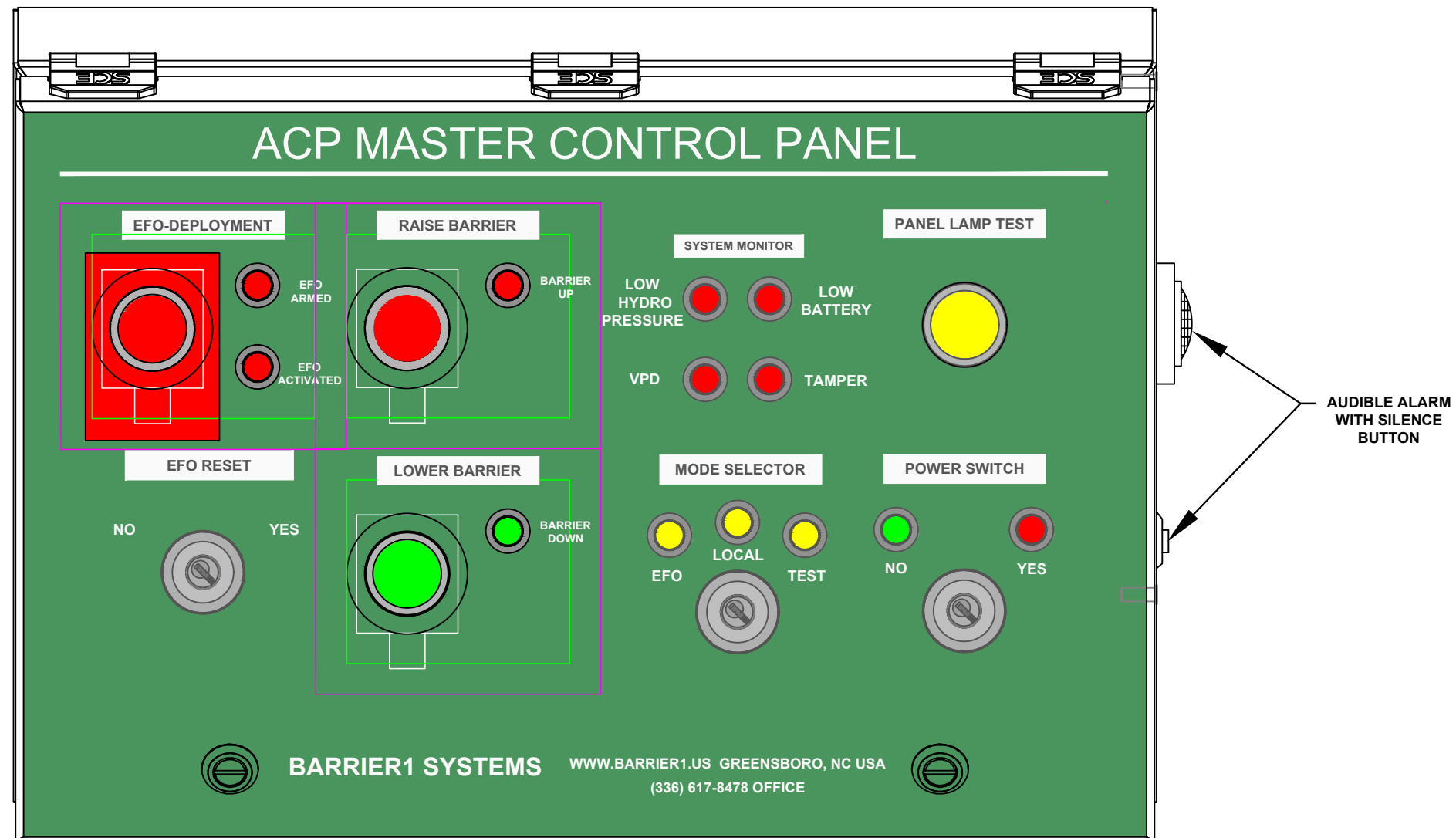

NOTE:
1. FINAL CONTROL LAYOUT TO BE DECIDED.



BARRIER1 SYSTEMS, LLC
5335 US HWY 220
SUMMERFIELD, NC 27358
(336) 617-8478 www.barrier1.com
sales@barrier1.com

PATENT PROTECTED

THE DRAWINGS AND INFORMATION CONTAINED HEREIN ARE PROPRIETARY AND CONFIDENTIAL, AND ARE AUTHORIZED ONLY FOR USE FOR WORK ASSOCIATED WITH BARRIER1 SYSTEMS, LLC ALL RIGHTS RESERVED.

MASTER CONTROL PANEL

HCB-ELE-1200
WEBSITE DRAWING

SHEET: 7 OF 12

20240718-10-M

SCALE: N.T.S.

B1 NIMITZ M50

HORIZONTAL CRASH BEAM - MODEL HCB-ELE-1200

CRASH TESTED TO ASTM F2656-07 - M50/P2 RATED - STOPS 15,000 LB. VEHICLE AT 50 MPH IMPACT

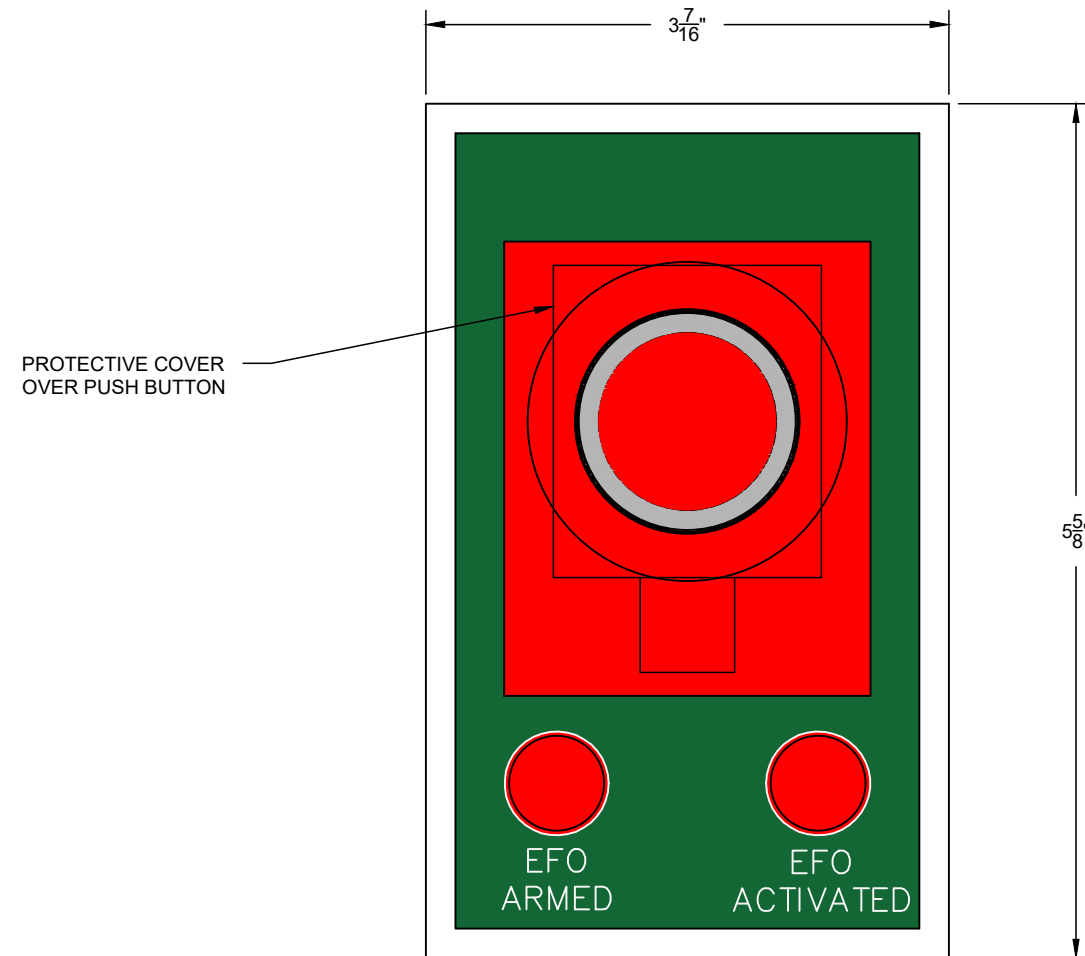

NOTE:
1. FINAL CONTROL LAYOUT TO BE DECIDED.



BARRIER1 SYSTEMS, LLC

5335 US HWY 220
SUMMERFIELD, NC 27358
(336) 617-8478 www.barrier1.com
sales@barrier1.com

PATENT PROTECTED

THE DRAWINGS AND INFORMATION CONTAINED HEREIN ARE PROPRIETARY AND CONFIDENTIAL, AND ARE AUTHORIZED ONLY FOR USE FOR WORK ASSOCIATED WITH BARRIER1 SYSTEMS, LLC ALL RIGHTS RESERVED.

REMOTE CONTROLLER

HCB-ELE-1200
WEBSITE DRAWING

SHEET: 8 OF 12

20240718-10-M

SCALE: N.T.S.

B1 NIMITZ M50

HORIZONTAL CRASH BEAM - MODEL HCB-ELE-1200

CRASH TESTED TO ASTM F2656-07 - M50/P2 RATED - STOPS 15,000 LB. VEHICLE AT 50 MPH IMPACT

LOCAL BARRIER CONTROLLERS

LOCAL CONTROLLER

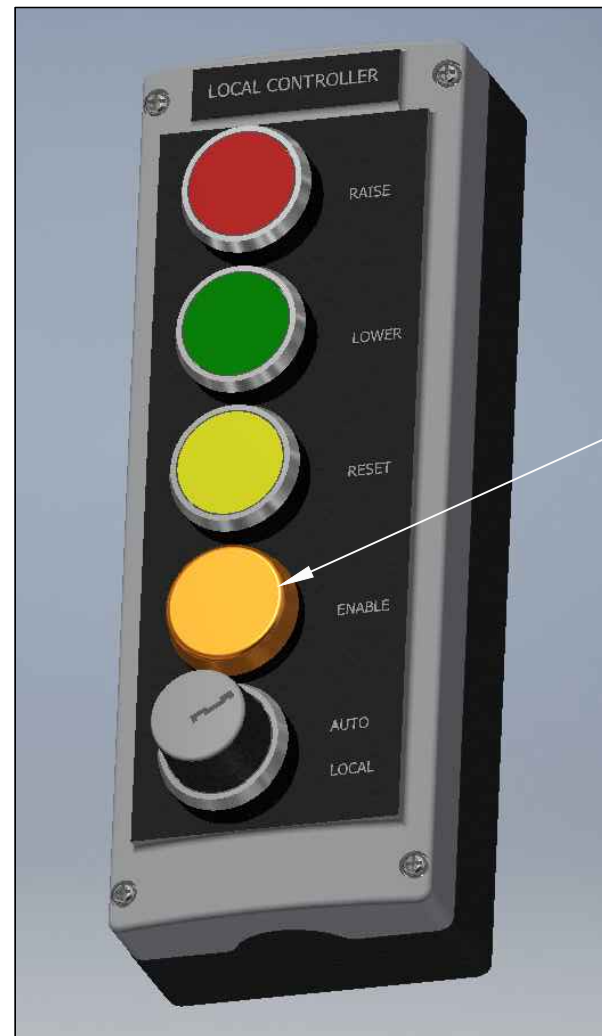

LAMP INDICATES THAT LOCAL CONTROLLER HAS BEEN ENABLED AT MASTER CONTROL PANEL.



BARRIER1 SYSTEMS, LLC

5335 US HWY 220
SUMMERFIELD, NC 27358
(336) 617-8478 www.barrier1.com
sales@barrier1.com

PATENT PROTECTED

THE DRAWINGS AND INFORMATION CONTAINED HEREIN ARE PROPRIETARY AND CONFIDENTIAL, AND ARE AUTHORIZED ONLY FOR USE FOR WORK ASSOCIATED WITH BARRIER1 SYSTEMS, LLC ALL RIGHTS RESERVED.

LOCAL CONTROLS

HCB-ELE-1200
WEBSITE DRAWING

SHEET: 9 OF 12

20240718-10-M

SCALE: N.T.S.

B1 NIMITZ M50

HORIZONTAL CRASH BEAM - MODEL HCB-ELE-1200

CRASH TESTED TO ASTM F2656-07 - M50/P2 RATED - STOPS 15,000 LB. VEHICLE AT 50 MPH IMPACT

CONTROLS COMMUNICATION SCHEMATIC

OPERATIONAL SEQUENCE PER SECOND (MIN. FOR SAFETY - 40 KPH (25MPH) DESIGN SPEED)

	ELAPSED TIME	0	1	2	3	4	5	6	7	8	9	10
TRAFFIC CONTROLS AND SAFETY AT ACTIVE BARRIER	TRAFFIC CONTROLS	NORMAL OPERATION	GUARD PERCEPTION AND REACTION TIME TO THREAT (EFO BUTTON) - 4 SECONDS						DEPLOYING BARRIER			THREAT CONTAINED
SIGN AND SIGNAL WARNING SYSTEM	WARNING SIGNS AND LIGHT WITH BEACONS	OFF	OFF	OFF	OFF	FLASHING YELLOW	FLASHING YELLOW	FLASHING YELLOW	FLASHING YELLOW	FLASHING YELLOW	FLASHING YELLOW	FLASHING YELLOW
	TRAFFIC SIGNAL	GREEN	GREEN	GREEN	GREEN	YELLOW	YELLOW	YELLOW	RED	RED	RED	RED
	AUDIBLE SIREN ALARM	OFF	OFF	OFF	OFF	ON	ON	ON	ON	ON	ON	ON
	SAFETY LOOP DETECTORS	ON	ON	ON	ON	ON	ON	ON	ON	ON	ON	ON
	ACTIVE BARRIER POSITION	DOWN	DOWN	DOWN	DOWN	DOWN	DOWN	DOWN	DOWN	ACTIVATED	ACTIVATED	ACTIVATED

NOTES:

1. SEQUENCING AND TIMING OF SIGNALS, ALARMS AND LIGHTS CAN BE FIELD ADJUSTED USING PLC.
2. SAFETY LOOP DETECTORS PREVENT DEPLOYMENT OF BARRIER IF A VEHICLE IS ABOVE LOOP. BARRIER DEPLOYS AFTER VEHICLE PASSES OVER THE SAFETY LOOPS.



BARRIER1 SYSTEMS, LLC

5335 US HWY 220
 SUMMERFIELD, NC 27358
 (336) 617-8478 www.barrier1.com
 sales@barrier1.com

PATENT PROTECTED

THE DRAWINGS AND INFORMATION CONTAINED HEREIN ARE PROPRIETARY AND CONFIDENTIAL, AND ARE AUTHORIZED ONLY FOR USE FOR WORK ASSOCIATED WITH BARRIER1 SYSTEMS, LLC ALL RIGHTS RESERVED.

TIME SEQUENCING DIAGRAM

HCB-ELE-1200
 WEBSITE DRAWING

SHEET: 10 OF 12

20240718-10-M

SCALE: N.T.S.

B1 NIMITZ M50

HORIZONTAL CRASH BEAM - MODEL HCB-ELE-1200

CRASH TESTED TO ASTM F2656-07 - M50/P2 RATED - STOPS 15,000 LB. VEHICLE AT 50 MPH IMPACT

END SUPPORT ENCLOSURES AND LOCKING ACCESS DOORS

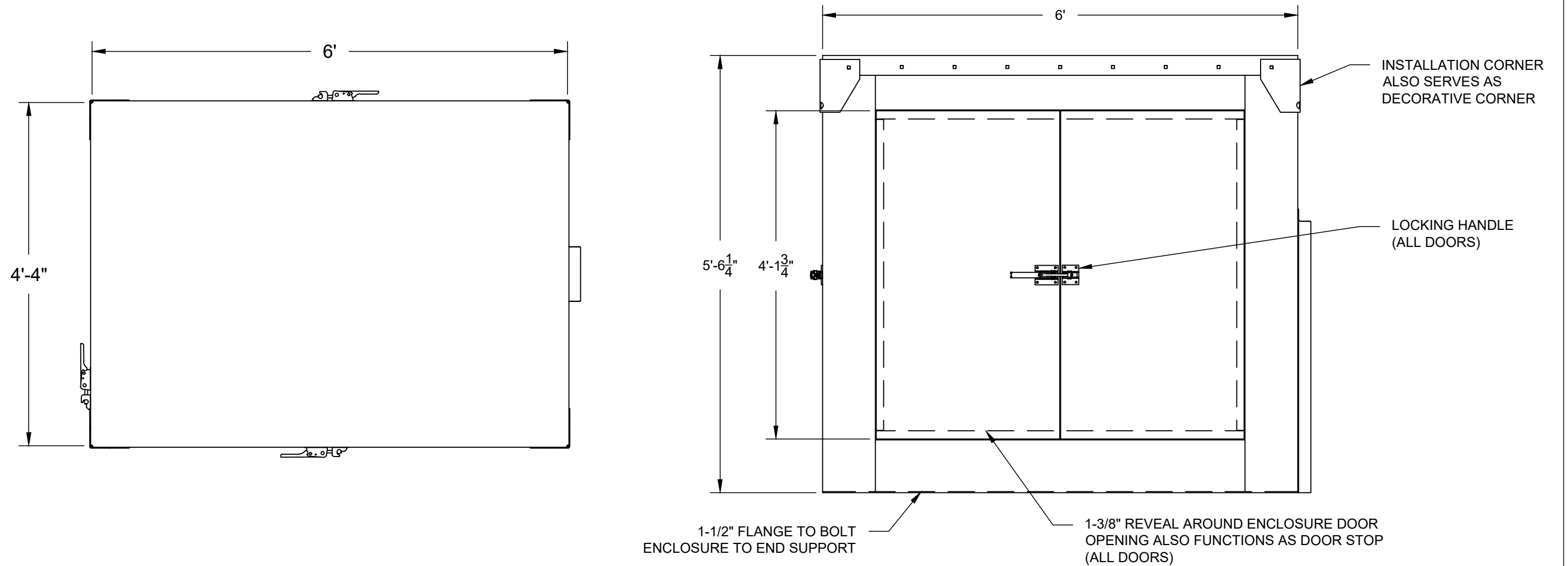

NOTES:

1. ENCLOSURE MATERIALS ARE 3/16" ALUMINUM WITH STANDARD PAINTED GRAY FINISH.
2. ENCLOSURES HAVE DOUBLE DOORS ON BOTH SIDES, AND A SINGLE DOOR IN REAR.



BARRIER1 SYSTEMS, LLC

5335 US HWY 220
SUMMERFIELD, NC 27358
(336) 617-8478 www.barrier1.com
sales@barrier1.com

PATENT PROTECTED

THE DRAWINGS AND INFORMATION CONTAINED HEREIN ARE PROPRIETARY AND CONFIDENTIAL, AND ARE AUTHORIZED ONLY FOR USE FOR WORK ASSOCIATED WITH BARRIER1 SYSTEMS, LLC ALL RIGHTS RESERVED.

ENCLOSURE DETAIL
(1 OF 2)

HCB-ELE-1200
WEBSITE DRAWING

SHEET: 11 OF 12

20240718-10-M

SCALE: N.T.S.

B1 NIMITZ M50

HORIZONTAL CRASH BEAM - MODEL HCB-ELE-1200

CRASH TESTED TO ASTM F2656-07 - M50/P2 RATED - STOPS 15,000 LB. VEHICLE AT 50 MPH IMPACT

CONTROL AND STATIC SIDE END SUPPORT ENCLOSURES

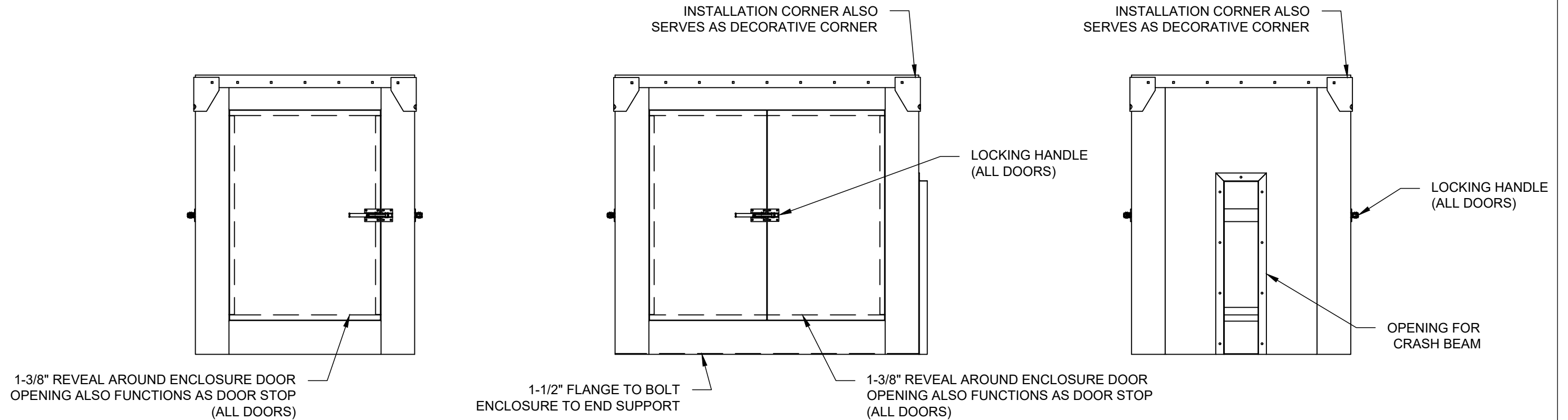

BARRIER1 SYSTEMS, LLC

5335 US HWY 220
SUMMERFIELD, NC 27358
(336) 617-8478 www.barrier1.com
sales@barrier1.com

PATENT PROTECTED

THE DRAWINGS AND INFORMATION CONTAINED HEREIN ARE PROPRIETARY AND CONFIDENTIAL, AND ARE AUTHORIZED ONLY FOR USE FOR WORK ASSOCIATED WITH BARRIER1 SYSTEMS, LLC ALL RIGHTS RESERVED.

ENCLOSURE DETAIL
(2 OF 2)

HCB-ELE-1200
WEBSITE DRAWING

SHEET: 12 OF 12

20240718-10-M

SCALE: N.T.S.